

DATA SHEET

P83CL781; P83CL782

Low voltage 8-bit microcontrollers
with UART and I²C-bus

Product specification
Supersedes data of 1995 Jul 13
File under Integrated Circuits, IC20

1997 Mar 14

Low voltage 8-bit microcontrollers with UART and I²C-bus

P83CL781; P83CL782

CONTENTS	14	STANDARD SERIAL INTERFACE SIO0: UART
1	FEATURES	14.1 Multiprocessor communications
2	GENERAL DESCRIPTION	14.2 Serial Port Control and Status Register (S0CON)
3	APPLICATIONS	14.3 Baud rates
4	ORDERING INFORMATION	15 INTERRUPT SYSTEM
5	BLOCK DIAGRAM	15.1 External interrupts INT2 to INT9
6	FUNCTIONAL DIAGRAM	15.2 Interrupt priority
7	PINNING INFORMATION	15.3 Interrupt registers
7.1	Pinning	16 OSCILLATOR CIRCUITRY
7.2	Pin description	17 RESET
8	FUNCTIONAL DESCRIPTION OVERVIEW	17.1 External reset using the RST pin
8.1	General	17.2 Power-on reset
8.2	CPU timing	18 SPECIAL FUNCTION REGISTERS OVERVIEW
9	MEMORY ORGANIZATION	19 INSTRUCTION SET
9.1	Program memory	20 LIMITING VALUES
9.2	Data memory	21 DC CHARACTERISTICS
9.3	Special Function Registers	22 AC CHARACTERISTICS
9.4	Addressing	22.1 Program memory
10	I/O FACILITIES	22.2 External Data Memory
10.1	Ports	23 PACKAGE OUTLINES
10.2	Port options	24 SOLDERING
10.3	Port 0 options	24.1 Introduction
10.4	SET/RESET options	24.2 DIP
11	TIMER/EVENT COUNTERS	24.3 QFP
11.1	Timer 0 and Timer 1	25 DEFINITIONS
11.2	Timer T2	26 LIFE SUPPORT APPLICATIONS
11.3	Timer/Counter 2 Control Register (T2CON)	27 PURCHASE OF PHILIPS I ² C COMPONENTS
12	REDUCED POWER MODES	
12.1	Idle mode	
12.2	Power-down mode	
12.3	Wake-up from Power-down mode	
12.4	Status of external pins	
12.5	Power Control Register (PCON)	
13	I ² C-BUS SERIAL I/O	
13.1	Serial Control Register (S1CON)	
13.2	Serial Status Register (S1STA)	
13.3	Data Shift Register (S1DAT)	
13.4	Address Register (S1ADR)	



Low voltage 8-bit microcontrollers with UART and I²C-bus

P83CL781; P83CL782

1 FEATURES

- Full static 80C51 CPU
- 8-bit CPU, ROM, RAM, I/O in a 40-lead DIP or 44-lead QFP package
- 16 kbytes ROM, expandable externally to 64 kbytes
- 256 bytes RAM, expandable externally to 64 kbytes
- Four 8-bit ports, 32 I/O lines
- Three 16-bit timer/event counters
- External memory expandable up to 128 kbytes: RAM up to 64 kbytes and ROM up to 64 kbytes
- On-chip oscillator suitable for RC, LC, quartz crystal or ceramic resonator
- Fifteen source, fifteen vector interrupt structure with two priority levels
- Full duplex serial port (UART)
- I²C-bus interface for serial transfer on two lines
- Enhanced architecture with:
 - non-page oriented instructions
 - direct addressing
 - four 8 byte RAM register banks
 - stack depth limited only by available internal RAM (maximum 256 bytes)
 - multiply, divide, subtract and compare instructions
- Reduced power consumption through Power-down and Idle modes
- Wake-up via external interrupts at Port 1
- Single supply voltage of 1.8 to 6.0 V
- Operating ambient temperature:
 - 83CL781: –40 to +85 °C
 - 83CL782: –25 to +55 °C.
- Frequency range of DC to 12 MHz
- Very low current consumption.

2 GENERAL DESCRIPTION

The term P83CL78x is used throughout this data sheet to refer to both the P83CL781 and P83CL782; differences between the devices are highlighted in the text.

The P83CL78x is manufactured in an advanced CMOS technology. The P83CL78x has the same instruction set as the 80C51, consisting of over 100 instructions: 49 one-byte, 46 two-byte, and 16 three-byte. The device has low power consumption and a wide range of supply voltage; there are two software-selectable modes of reduced activity for further power reduction: Idle and Power-down. For emulation purposes, the P85CL781 (piggy-back version) with 256 bytes of RAM is recommended.

The P83CL782 is a faster version of the P83CL781 and operates at a maximum frequency of 12 MHz at $V_{DD} \geq 3.1$ V.

This data sheet details the specific properties of the P83CL78x. For details of the 80C51 core and the I²C-bus see "Data Handbook IC20".

3 APPLICATIONS

The P83CL78x is an 8-bit general purpose microcontroller especially suited for cordless telephone applications. The P83CL78x also functions as an arithmetic processor having facilities for both binary and BCD arithmetic plus bit-handling capabilities.

Low voltage 8-bit microcontrollers with UART and I²C-bus

P83CL781; P83CL782

4 ORDERING INFORMATION

TYPE NUMBER ⁽¹⁾	PACKAGE		
	NAME	DESCRIPTION	VERSION
P83CL781HFP	DIP40	plastic dual in-line package; 40 leads (600 mil)	SOT129-1
P83CL782HDP			
P83CL781HFH	QFP44	plastic quad flat package; 44 leads (lead length 2.35 mm); body 14 × 14 × 2.2 mm	SOT205-1
P83CL782HDH			
P83CL781HFH	QFP44	plastic quad flat package; 44 leads (lead length 1.3 mm); body 10 × 10 × 1.75 mm	SOT307-2
P83CL781HDH			

Note

1. Refer to the Order Entry Form (OEF) for this device for the full type number, including options/program.

Low voltage 8-bit microcontrollers with UART and I²C-bus

P83CL781; P83CL782

5 BLOCK DIAGRAM

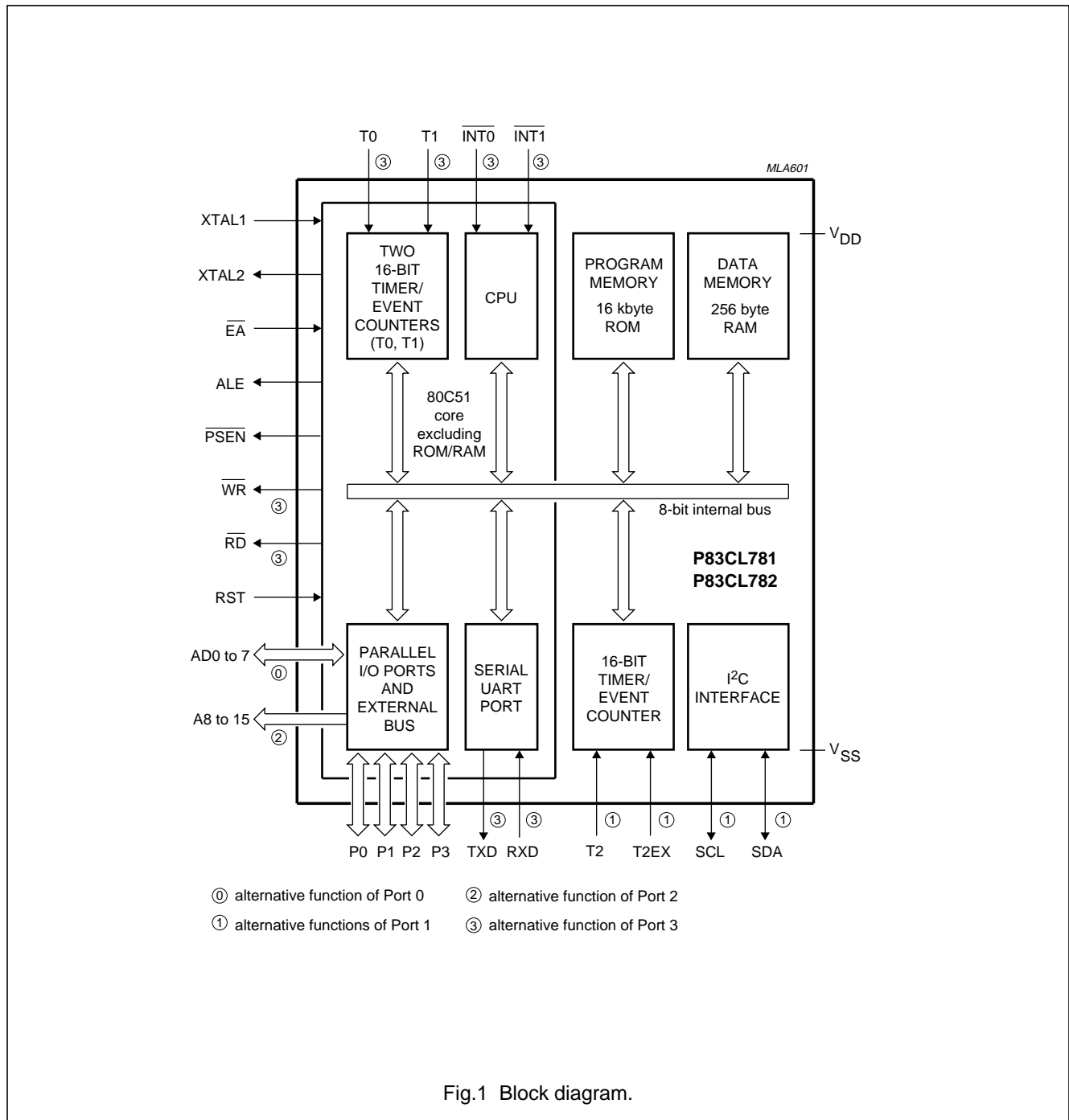

Low voltage 8-bit microcontrollers with UART and I²C-bus

P83CL781; P83CL782

6 FUNCTIONAL DIAGRAM

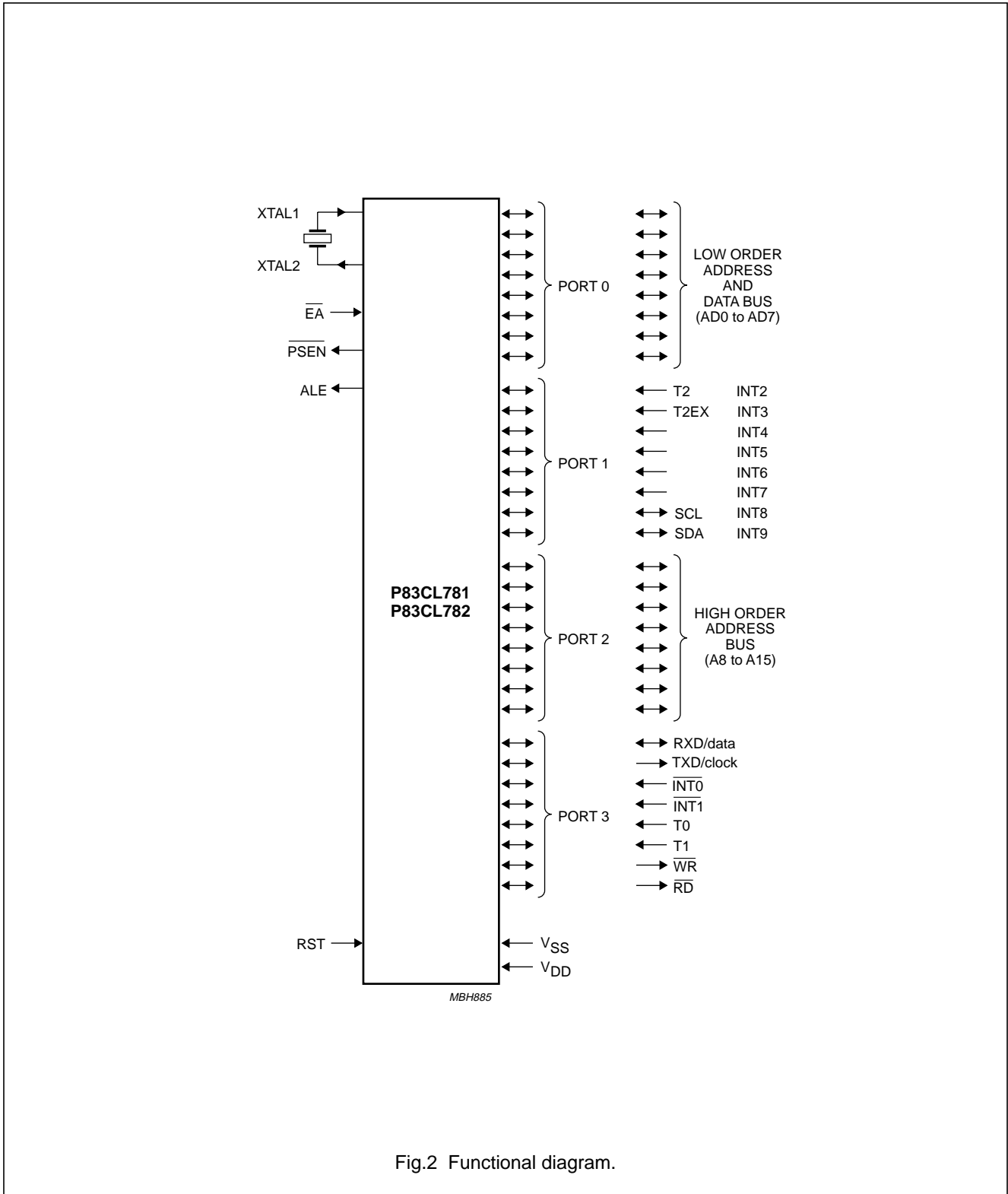

Fig.2 Functional diagram.

Low voltage 8-bit microcontrollers with
UART and I²C-bus

P83CL781; P83CL782

7 PINNING INFORMATION

7.1 Pinning

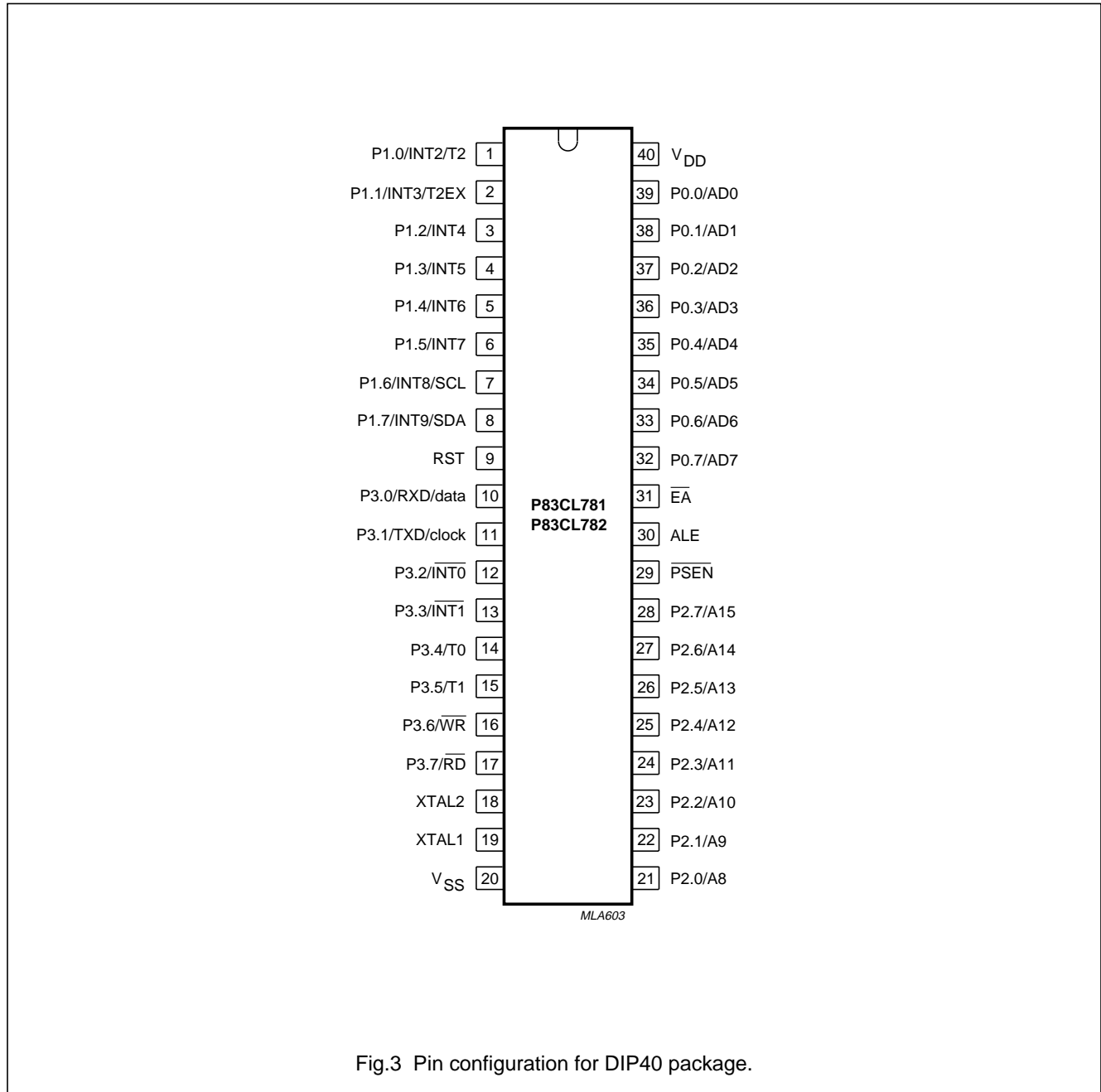

Low voltage 8-bit microcontrollers with
UART and I²C-bus

P83CL781; P83CL782

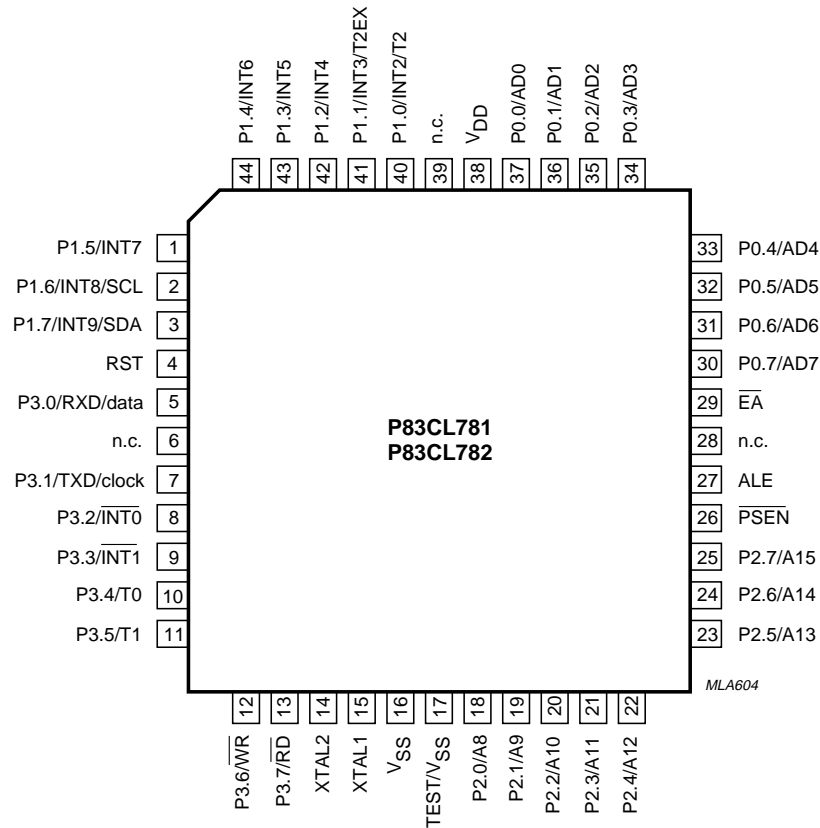

Fig.4 Pin configuration for QFP44 packages.

Low voltage 8-bit microcontrollers with UART and I²C-bus

P83CL781; P83CL782

7.2 Pin description

SYMBOL	PIN		DESCRIPTION
	DIP40	QFP44	
P1.0/INT2/T2	1	40	<ul style="list-style-type: none"> • Port 1: 8-bit bidirectional I/O port (P1.0 to P1.7). Port pins that have logic 1s written to them are pulled HIGH by internal pull-ups, and in this state can be used as inputs (note that P1.6 and P1.7 are open-drain only). As inputs, Port 1 pins that are externally pulled LOW will source current (I_{IL}) due to the internal pull-ups. Port 1 output buffers can sink/source 4 LS TTL loads. • Alternative functions: <ul style="list-style-type: none"> – INT2 to INT9 are external interrupt inputs – T2 and T2EX are the Timer/event counter 2 inputs – SCL and SDA are the I²C-bus clock and data lines.
P1.1/INT3/T2EX	2	41	
P1.2/INT4	3	42	
P1.3/INT5	4	43	
P1.4/INT6	5	44	
P1.5/INT7	6	1	
P1.6/INT8/SCL	7	2	
P1.7/INT9/SDA	8	3	
RST	9	4	Reset: A HIGH level on this pin for two machine cycles while the oscillator is running, resets the device.
n.c.	–	6	Not connected.
P3.0/RXD/data	10	5	<ul style="list-style-type: none"> • Port 3: 8-bit bidirectional I/O port (P3.0 to P3.7). Same characteristics as Port 1. • Alternative functions: <ul style="list-style-type: none"> – RXD/data is the UART serial data input (asynchronous) or data I/O (synchronous) – TXD/clock is the UART serial data output (asynchronous) or clock output (synchronous) – $\overline{\text{INT0}}$ and $\overline{\text{INT1}}$ are external interrupt lines – T0 and T1 are external inputs for Timer 0 and Timer 1 respectively – $\overline{\text{WR}}$ is the external memory write strobe and $\overline{\text{RD}}$ is the external memory read strobe.
P3.1/TXD/clock	11	7	
P3.2/ $\overline{\text{INT0}}$	12	8	
P3.3/ $\overline{\text{INT1}}$	13	9	
P3.4/T0	14	10	
P3.5/T1	15	11	
P3.6/ $\overline{\text{WR}}$	16	12	
P3.7/ $\overline{\text{RD}}$	17	13	
XTAL2	18	14	Crystal Output: Output of the inverting amplifier that forms the oscillator. Left open-circuit when an external oscillator clock is used.
XTAL1	19	15	Crystal Input: Input to the inverting amplifier that forms the oscillator, also the input for an externally generated clock source.
V _{SS}	20	16	Ground: Circuit ground potential.
TEST/V _{SS}	–	17	Test Input: Must be connected to V _{SS} or left open.
P2.0/A8	21	18	<ul style="list-style-type: none"> • Port 2: 8-bit bidirectional I/O port (P2.0 to P2.7). Same characteristics as Port 1. • High-order addressing: A8 to A15 make up the high-order address byte during accesses to external memory that use 16-bit addresses (MOVX@DPTR). In this application the pins use the strong internal pull-ups when emitting logic 1's. During accesses to external memory that use 8-bit addresses (MOVX@Ri), the pins emit the contents of the P2 Special Function Register.
P2.1/A9	22	19	
P2.2/A10	23	20	
P2.3/A11	24	21	
P2.4/A12	25	22	
P2.5/A13	26	23	
P2.6/A14	27	24	
P2.7/A15	28	25	

Low voltage 8-bit microcontrollers with UART and I²C-bus

P83CL781; P83CL782

SYMBOL	PIN		DESCRIPTION
	DIP40	QFP44	
$\overline{\text{PSEN}}$	29	26	Program Store Enable: Read strobe to external Program Memory. When executing code out of external Program Memory, $\overline{\text{PSEN}}$ is activated twice each machine cycle. However, during each access to external Data Memory two $\overline{\text{PSEN}}$ activations are skipped.
ALE	30	27	Address Latch Enable: Latches the low byte of the address during accesses to external memory. It is activated every six oscillator periods and may be used for external timing or clocking purposes.
n.c.	–	28	Not connected.
$\overline{\text{EA}}$	31	29	External Access: When $\overline{\text{EA}}$ is held HIGH, the CPU executes out of the internal Program Memory (unless the Program Counter exceeds 3FFFH). When $\overline{\text{EA}}$ is held LOW, the CPU executes out of external Program Memory regardless of the value of the program counter.
P0.7/AD7	32	30	<ul style="list-style-type: none"> • Port 0: 8-bit open-drain bidirectional I/O port (P0.7 to P0.0). As an open-drain output port it can sink/source 8 LS TTL loads. Port 0 pins that have logic 1s written to them float, and in this state will function as high-impedance inputs. • Low-order addressing: AD7 to AD0 provide the multiplexed low-order address and data bus during accesses to external memory. In this application the pins use the strong internal pull-ups when emitting logic 1s.
P0.6/AD6	33	31	
P0.5/AD5	34	32	
P0.4/AD4	35	33	
P0.3/AD3	36	34	
P0.2/AD2	37	35	
P0.1/AD1	38	36	
P0.0/AD0	39	37	
V _{DD}	40	38	Power supply.
n.c.	–	39	Not connected.

Low voltage 8-bit microcontrollers with UART and I²C-bus

P83CL781; P83CL782

8 FUNCTIONAL DESCRIPTION OVERVIEW

This chapter gives a brief overview of the device. The detailed functional description is in the following chapters:

Chapter 9 "Memory organization"

Chapter 10 "I/O facilities"

Chapter 11 "Timer/event counters"

Chapter 12 "Reduced power modes"

Chapter 13 "I²C-bus serial I/O"

Chapter 14 "Standard serial interface SIO0: UART"

Chapter 15 "Interrupt system"

Chapter 16 "Oscillator circuitry"

Chapter 17 "Reset".

8.1 General

The P83CL78x is a stand-alone high-performance CMOS microcontroller designed for use in real-time applications such as instrumentation, industrial control, intelligent computer peripherals and consumer products. The device provides hardware features, architectural enhancements and new instructions to function as a controller for applications requiring up to 64 kbytes of Program Memory and/or up to 64 kbytes of data storage.

The P83CL78x contains a non-volatile 16 kbyte read-only Program Memory; a static 256 byte read/write Data Memory; 32 I/O lines; three 16-bit timer/event counters; a fifteen-source, two priority-level, nested interrupt structure and on-chip oscillator and timing circuit.

The device has two software-selectable modes of reduced activity for power reduction:

- **Idle mode**; freezes the CPU while allowing the timers, serial I/O and interrupt system to continue functioning.
- **Power-down mode**; saves the RAM contents but freezes the oscillator causing all other chip functions to be inoperative.

In addition, two serial interfaces are provided on-chip:

- a standard UART serial interface, and
- a standard I²C-bus serial interface. The I²C-bus serial interface has byte-oriented master and slave functions allowing communication with the whole family of I²C-bus compatible devices.

8.2 CPU timing

A machine cycle consists of a sequence of 6 states. Each state lasts for two oscillator periods, thus a machine cycle takes 12 oscillator periods or 1 μ s if the oscillator frequency (f_{osc}) is 12 MHz.

Low voltage 8-bit microcontrollers with UART and I²C-bus

P83CL781; P83CL782

9 MEMORY ORGANIZATION

The P83CL78x has a 16 kbyte Program Memory (ROM) plus 256 bytes of Data Memory (RAM) on-chip. The device has separate address spaces for Program and Data Memory (see Fig.6). Using Ports P0 and P2, the P83CL78x can address up to 128 kbytes of external memory. The CPU generates both read (\overline{RD}) and write (\overline{WR}) signals for external Data Memory accesses, and the read strobe (\overline{PSEN}) for external Program Memory.

9.1 Program memory

The P83CL78x contains 16 kbytes of internal ROM. After reset the CPU begins execution at location 0000H. The lower 16 kbytes of Program Memory can be implemented in either on-chip ROM or external memory. If the EA pin is strapped to V_{DD}, then Program Memory fetches from addresses 0000H through to 3FFFH are directed to the internal ROM. Fetches from addresses 4000H through to FFFFH are directed to external ROM. Program Counter values greater than 3FFFH are automatically addressed to external memory regardless of the state of the EA pin.

9.2 Data memory

The P83CL78x contains 256 bytes of internal RAM and 34 Special Function Registers (SFRs). The memory map (Fig.6) shows the internal Data Memory space divided into the lower 128 bytes, the upper 128 bytes and the SFR space. Internal RAM locations 0 to 127 are directly and indirectly addressable. Internal RAM locations 128 to 255 are only indirectly addressable. The Special Function Register locations 128 to 255 bytes are only directly addressable.

9.3 Special Function Registers

The upper 128 bytes are the address locations of the Special Function Registers. Figures 7 and 8 show the Special Function Registers space. The SFRs include the port latches, timers, peripheral control, serial I/O registers, and so on. These registers can only be accessed by direct addressing. There are 128 addressable locations in the SFR address space (SFRs with addresses divisible by eight).

9.4 Addressing

The P83CL78x has five methods for addressing source operands:

- Register
- Direct
- Register-indirect
- Immediate
- Base-register plus index-register-indirect.

The first three methods can be used for addressing destination operands. Most instructions have a 'destination/source' field that specifies the data type, addressing methods and operands involved. For operations other than MOVs, the destination operand is also a source operand.

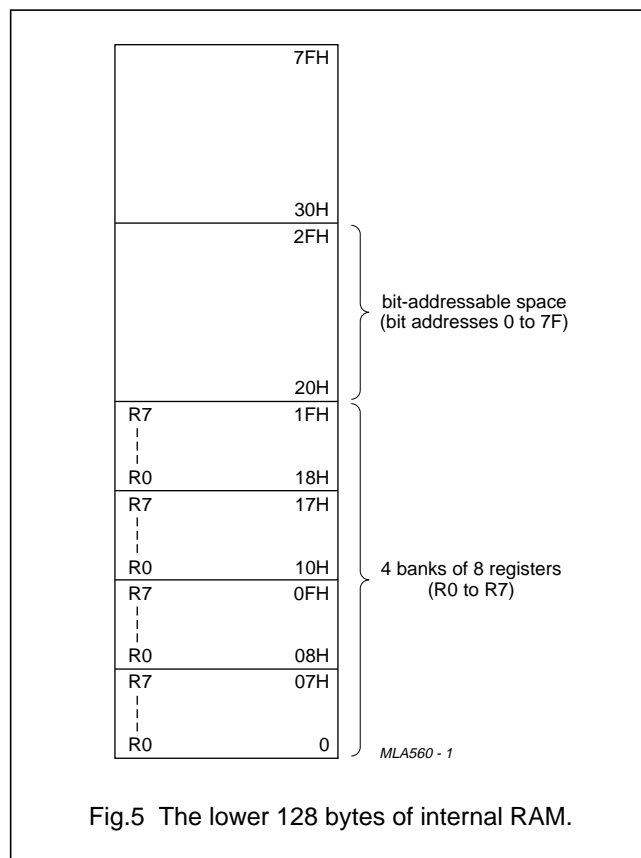

Fig.5 The lower 128 bytes of internal RAM.

Low voltage 8-bit microcontrollers with UART and I²C-bus

P83CL781; P83CL782

Access to memory addressing is as follows:

- Registers in one of the four register banks through register, direct or register-indirect
- 256 bytes of internal data RAM through direct or register-indirect
- Special Function Registers through direct
- External Data Memory through register-indirect
- Program Memory look-up tables through base-register plus index-register-indirect.

The P83CL78x is classified as an 8-bit device since the internal ROM, RAM, Special Function Registers, Arithmetic Logic Unit and external data bus are all 8-bits wide. It performs operations on bit, nibble, byte and double-byte data types.

Facilities are available for byte transfer, logic and integer arithmetic operations. Data transfer, logic and conditional branch operations can be performed directly on Boolean variables to provide excellent bit handling.

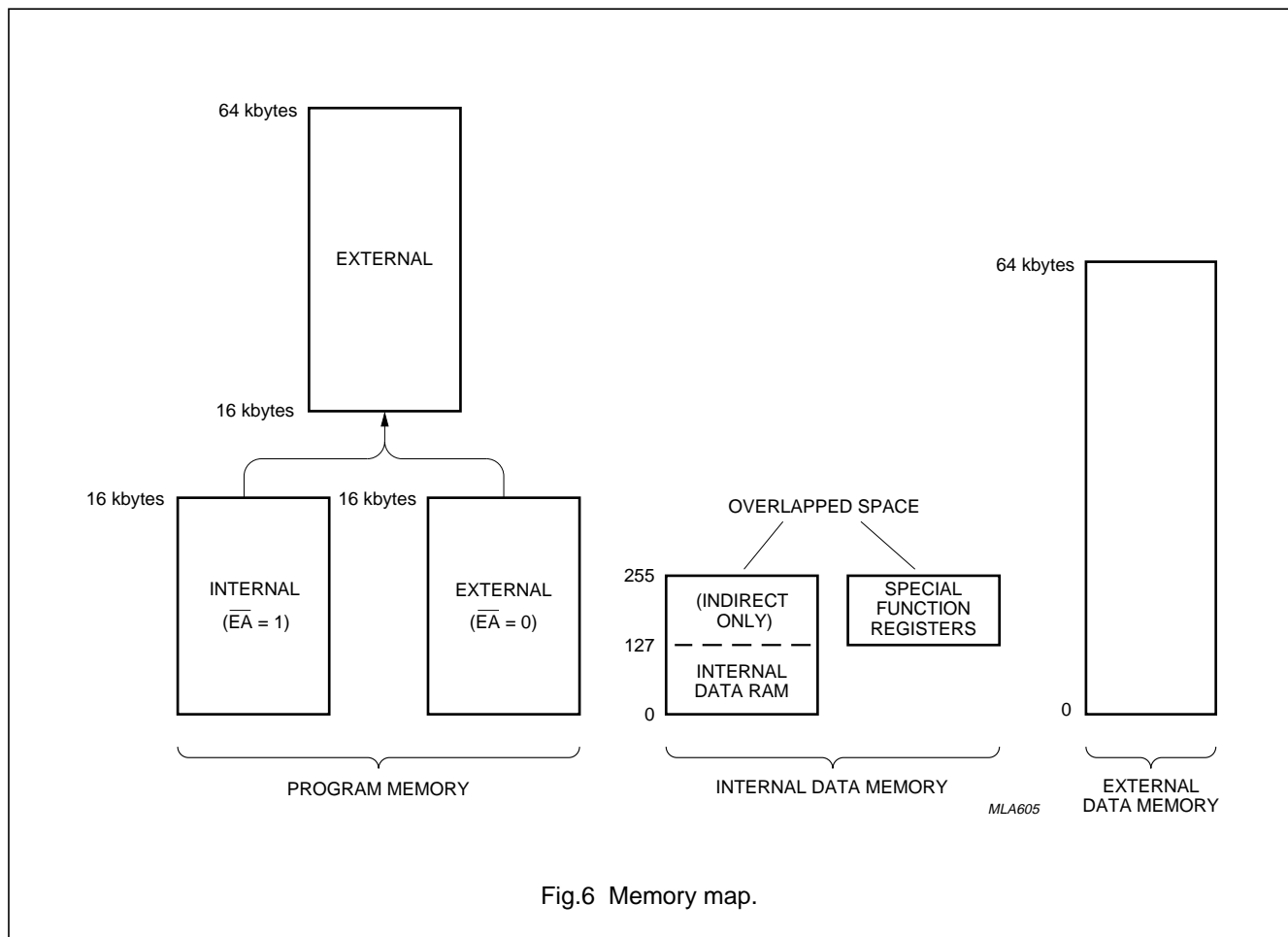

Fig.6 Memory map.

Low voltage 8-bit microcontrollers with
UART and I²C-bus

P83CL781; P83CL782

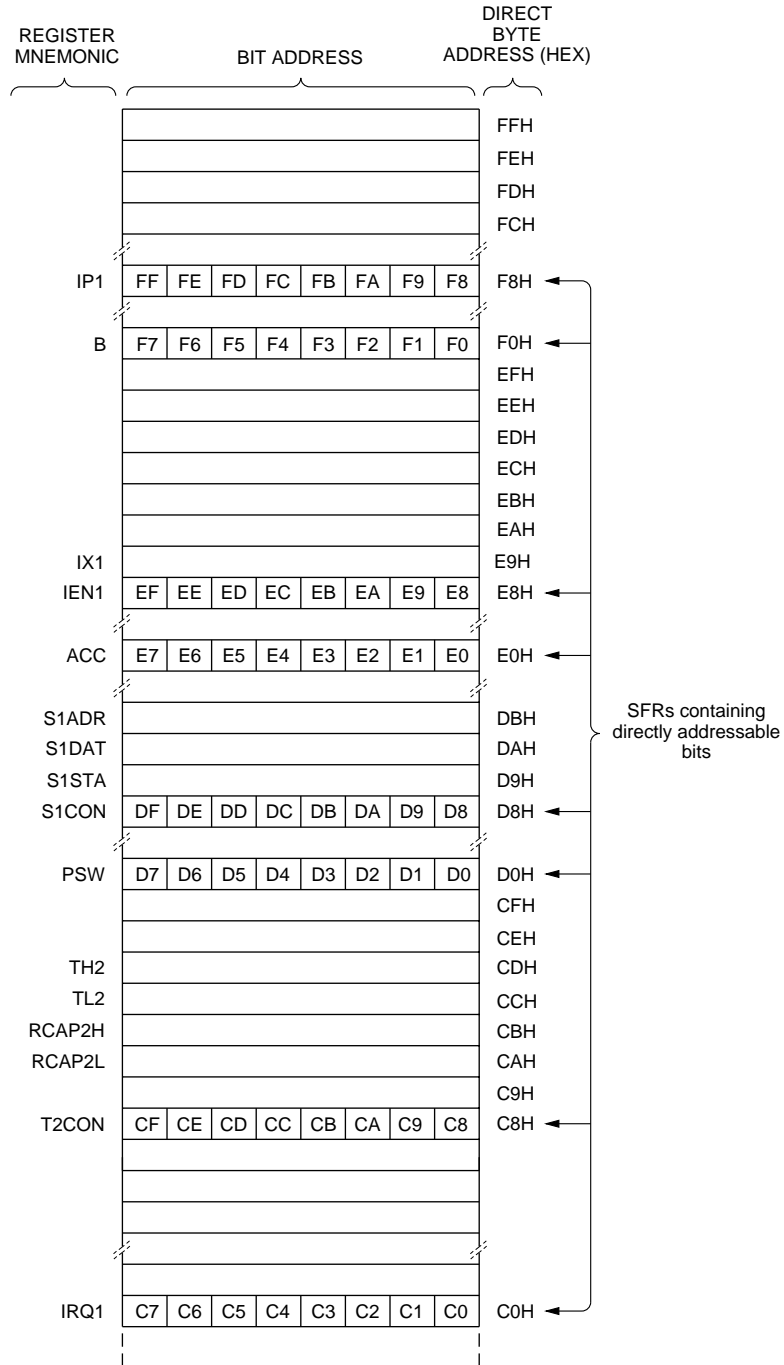

Fig.7 Special Function Register memory map (continued in Fig.8).

Low voltage 8-bit microcontrollers with
UART and I²C-bus

P83CL781; P83CL782

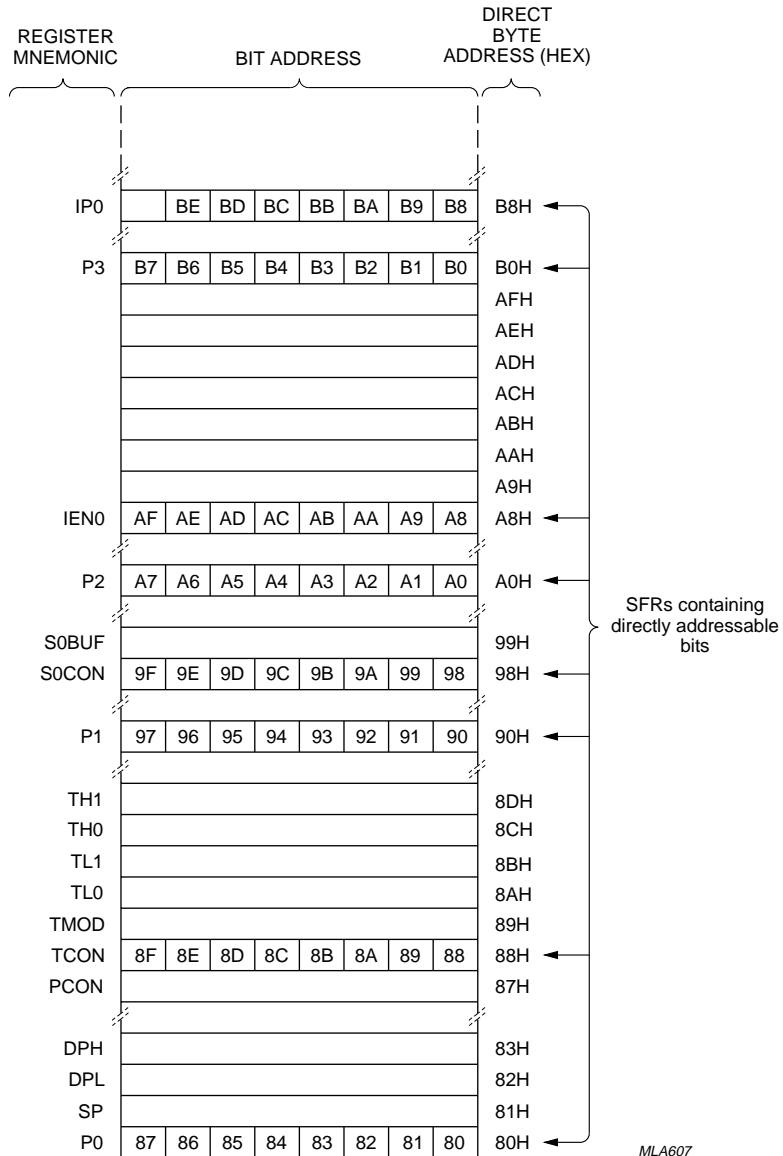

Fig.8 Special Function Register memory map (continued from Fig.7).

Low voltage 8-bit microcontrollers with UART and I²C-bus

P83CL781; P83CL782

10 I/O FACILITIES

10.1 Ports

The P83CL78x has 32 I/O lines treated as 32 individually addressable bits or as four parallel 8-bit ports. To enable a port pin alternative function, the port bit latch in its SFR must contain a logic 1. The alternative functions are detailed below:

Port 0 Provides the multiplexed low-order address and data bus for expanding the device with standard memories and peripherals.

Port 1 Used for a number of special functions:

- Provides the inputs for the eight external interrupts: INT2 to INT9
- External activation of Timer 2: T2
- The I²C-bus interface: SCL and SDA.

Port 2 Provides the high-order address when expanding the device with external Program or Data memory.

Port 3 Pins can be configured individually to provide:

- External interrupt request inputs: $\overline{\text{INT1}}$ and $\overline{\text{INT0}}$
- Timer/counter inputs: T1 and T0
- Control signals to read and write to external memories: $\overline{\text{RD}}$ and $\overline{\text{WR}}$
- UART asynchronous input and output (RXD and TXD); or UART synchronous I/O and clock lines (data and clock).1

Each port consists of a latch (SFRs P0 to P3), an output driver and input buffer. Ports 1, 2 and 3 have internal pull-ups (except P1.6 and P1.7). Figure 9(a) shows that the strong transistor 'p1' is turned on for only 2 oscillator periods after a LOW-to-HIGH transition in the port latch. When on, it turns on p3 (a weak pull-up) through the inverter. This inverter and p3 form a latch which holds the logic 1. In Port 0 the pull-up 'p1' is only on when emitting logic 1s for external memory access. Writing a logic 1 to a Port 1 bit latch leaves both output transistors switched off so that the pin can be used as an high-impedance input.

10.2 Port options

30 of the 32 port pins (excluding P1.6 and P1.7 with option 2S only) may be individually configured with one of the following options. These options are also shown in Fig.9.

Option 1 Standard Port; quasi-bidirectional I/O with pull-up. The strong booster pull-up 'p1' is turned on for two oscillator periods after a

LOW-to-HIGH transition in the port latch; Fig.9(a).

Option 2 Open-drain; quasi-bidirectional I/O with n-channel open-drain output. Use as an output requires the connection of an external pull-up resistor; Fig.9(b).

Option 3 Push-Pull; output with drive capability in both polarities. Under this option, pins can only be used as outputs; Fig.9(c).

10.3 Port 0 options

The definition of port options for Port 0 is slightly different. Two cases are considered. First, access to external memory ($\overline{\text{EA}} = 0$ or access above the built-in memory boundary) and second, I/O accesses.

10.3.1 EXTERNAL MEMORY ACCESSES

Option 1 True logic 0 and logic 1 are written as address to the external memory (strong pull-up to be used).

Option 2 An external pull-up resistor is required for external accesses.

Option 3 Not allowed for external memory accesses as the port can only be used as output.

10.3.2 I/O ACCESSES

Option 1 When writing a logic 1 to the port latch, the strong pull-up 'p1' will be on for 2 oscillator periods. No weak pull-up exists. Without an external pull-up, this option can be used as a high-impedance input.

Option 2 Open-drain; quasi-directional I/O with n-channel open-drain output. Use as an output requires the connection of an external pull-up resistor. See Fig.9(b).

Option 3 Push-Pull; output with drive capability in both polarities. Under this option pins can only be used as outputs. See Fig.9(c).

10.4 SET/RESET options

Individual mask selection of the post-reset state is available with any of the above pins. The required selection is made by appending 'S' or 'R' to Options 1, 2, or 3 above.

Option R RESET, at reset this pin will be initialized LOW.

Option S SET, at reset this pin will be initialized HIGH.

Low voltage 8-bit microcontrollers with
UART and I²C-bus

P83CL781; P83CL782

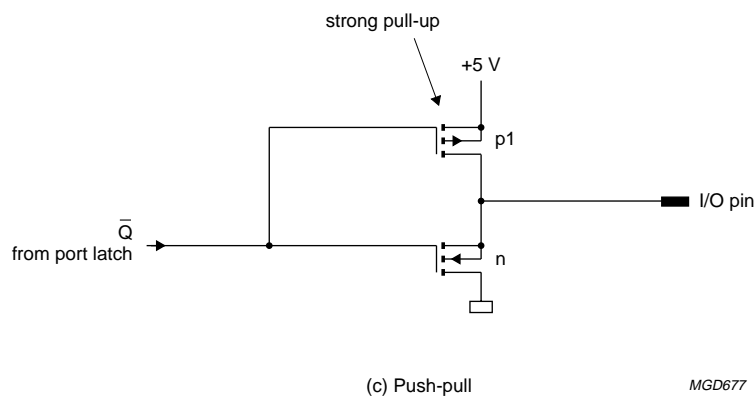
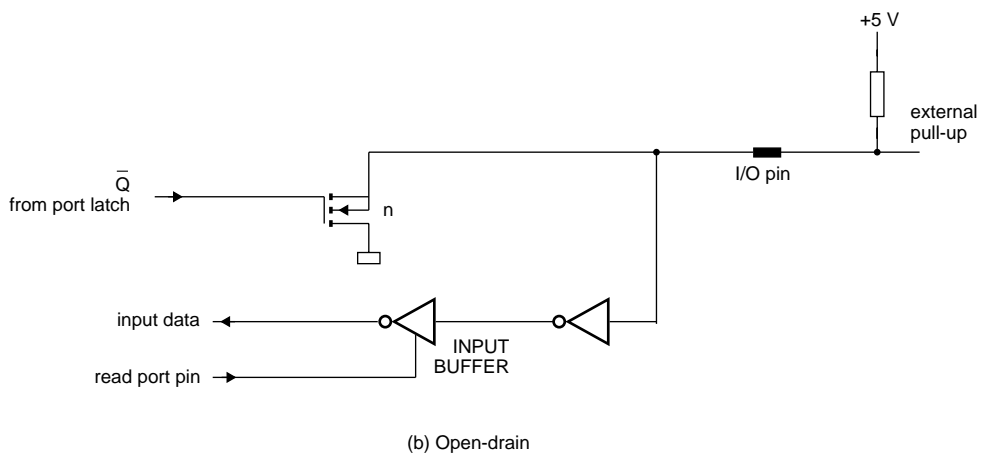
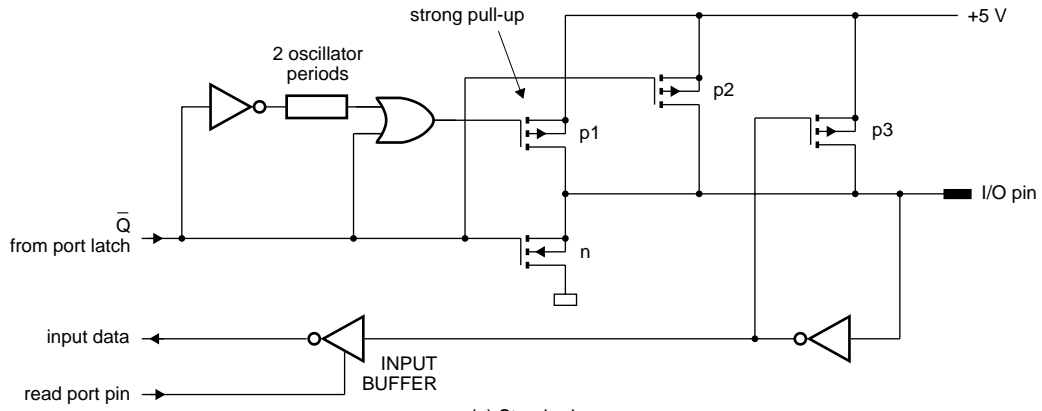

MGD677

Fig.9 Port configuration options.

Low voltage 8-bit microcontrollers with UART and I²C-bus

P83CL781; P83CL782

11 TIMER/EVENT COUNTERS

The P83CL78x contains three 16-bit timer/event counter registers; Timer 0, Timer 1 and Timer 2 which can perform the following functions:

- Measure time intervals and pulse durations
- Count events
- Generate interrupt requests.

In the 'Timer' operating mode the register is incremented every machine cycle. Since a machine cycle consists of 12 oscillator periods, the count rate is $\frac{1}{12} \times f_{osc}$.

In the 'Counter' operating mode, the register is incremented in response to a HIGH-to-LOW transition. Since it takes 2 machine cycles (24 oscillator periods) to recognize a HIGH-to-LOW transition, the maximum count rate is $\frac{1}{24} \times f_{osc}$. To ensure a given level is sampled, it should be held for at least one complete machine cycle.

11.1 Timer 0 and Timer 1

Timer 0 and Timer 1 can be programmed independently to operate in four modes:

- Mode 0 8-bit timer or 8-bit counter each with divide-by-32 prescaler.
- Mode 1 16-bit time-interval or event counter.
- Mode 2 8-bit time-interval or event counter with automatic reload upon overflow.
- Mode 3 Timer 0 establishes TL0 and TH0 as two separate counters.

11.2 Timer T2

Timer T2 is a 16-bit timer/counter that can operate (like Timer 0 and 1) either as a timer or as an event counter. These functions are selected by the state of the $C/\overline{T2}$ bit in the T2CON register; see Tables 1 and 2.

Three operating modes are available Capture, Auto-reload and Baud Rate Generator, which also are selected via the T2CON register; see Table 3.

11.2.1 CAPTURE MODE

Figure 10 shows the Capture mode. Two options in this mode, may be selected by the EXEN2 bit in T2CON:

- If EXEN2 = 0, then Timer 2 is a 16-bit timer or counter which upon overflowing sets the Timer 2 overflow bit TF2, this may then be used to generate an interrupt.
- If EXEN2 = 1, Timer 2 operates as described above but with the additional feature that a HIGH-to-LOW transition at external input T2EX causes the current value in TL2 and TH2 to be captured into registers RCAP2L and RCAP2H respectively. In addition, the transition at T2EX causes the EXF2 bit in T2CON to be set; this may also be used to generate an interrupt.

11.2.2 AUTO-RELOAD MODE

Figure 11 shows the Auto-reload mode. Also two options in this mode are selected by the EXEN2 bit in T2CON:

- If EXEN2 = 0, then when Timer 2 rolls over, it sets the TF2 bit but also causes the Timer 2 registers to be reloaded with the 16-bit value held in registers RCAP2L and RCAP2H. The 16-bit value held in these registers is preset by software.
- If EXEN2 = 1, Timer 2 operates as described above but with the additional feature that a HIGH-to-LOW transition at external input T2EX will also trigger the 16-bit reload and set the EXF2 bit.

11.2.3 BAUD RATE GENERATOR MODE

The Baud Rate Generator mode is selected when RTCLK = 1. It will be described in conjunction with the serial port (UART); see Section 14.3.2.

Low voltage 8-bit microcontrollers with
UART and I²C-bus

P83CL781; P83CL782

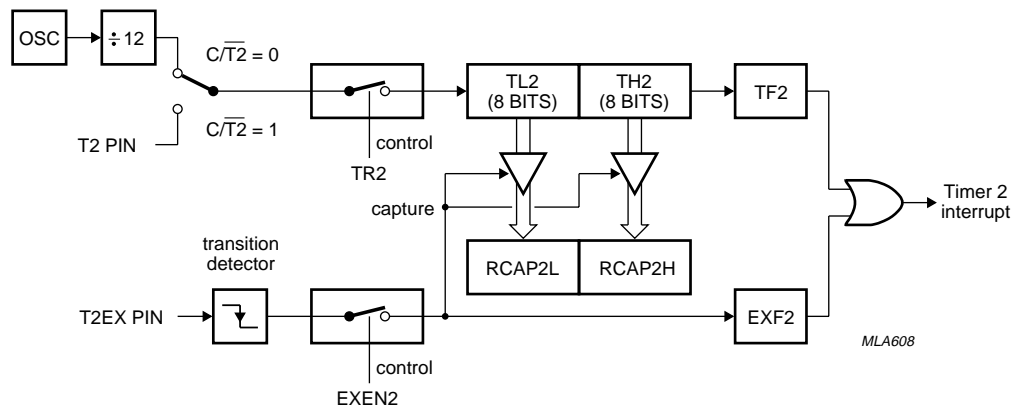

Fig.10 Timer 2 in Capture mode.

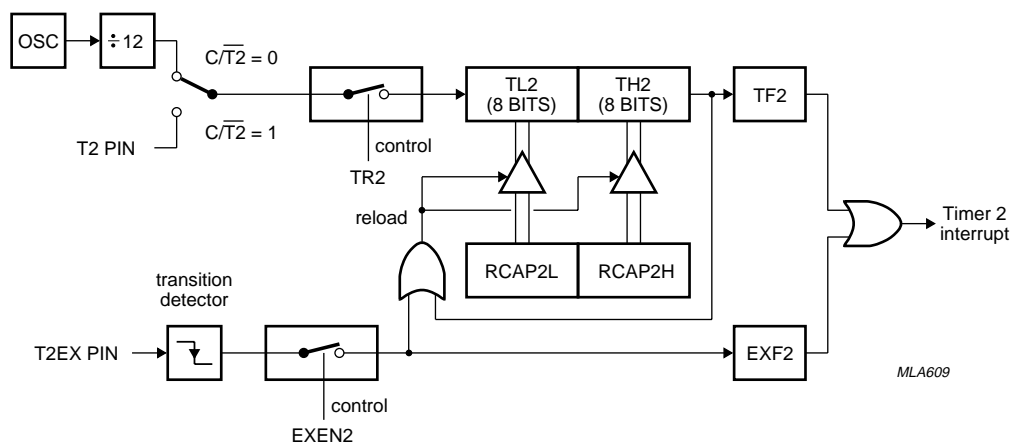

Fig.11 Timer 2 in Auto-Reload mode.

Low voltage 8-bit microcontrollers with UART and I²C-bus

P83CL781; P83CL782

11.3 Timer/Counter 2 Control Register (T2CON)

Table 1 Timer/Counter 2 Control Register (SFR address C8H)

7	6	5	4	3	2	1	0
TF2	EXF2	GF2	RTCLK	EXEN2	TR2	C/T $\bar{2}$	CP/RL $\bar{2}$

Table 2 Description of T2CON bits

BIT	SYMBOL	DESCRIPTION
7	TF2	Timer 2 overflow flag. Set by a Timer 2 overflow and must be cleared by software. TF2 will not be set when RTCLK = 1.
6	EXF2	Timer 2 external flag. Set when either a capture or reload is caused by a negative transition on T2EX and when EXEN2 = 1. When Timer T2 interrupt is enabled, EXF2 = 1 will cause the CPU to vector to Timer 2 interrupt routine. EXF2 must be cleared by software.
5	GF2	General purpose flag bit.
4	RTCLK	Receive/transmit clock flag. When set, causes the UART serial port to use Timer 2 overflow pulses for its receive and transmit clock in Modes 1 and 3. RTCLK = 0 causes Timer 1 overflows to be used for the receive and transmit clock.
3	EXEN2	Timer 2 external enable flag. When set, allows a capture or reload to occur as a result of a negative transition on T2EX, if Timer 2 is not being used to clock the serial port. EXEN2 = 0, causes Timer 2 to ignore events at T2EX.
2	TR2	Start/stop control for Timer 2. TR2 = 1 starts the timer.
1	C/T $\bar{2}$	Timer or counter select for Timer 2. C/T $\bar{2}$ = 0 selects the internal timer with a clock frequency of $\frac{1}{12} \times f_{osc}$. C/T $\bar{2}$ = 1 selects the external event counter; negative edge triggered.
0	CP/RL $\bar{2}$	Capture/Reload flag. When set, captures will occur on negative transitions at T2EX, if EXEN2 = 1. When cleared, auto-reloads will occur either with Timer 2 overflows or negative transitions at T2EX when EXEN2 = 1. When RTCLK = 1, this bit is ignored and the timer is forced to auto-reload on a Timer 2 overflow.

Table 3 Timer 2 operating modes; X = don't care

RTCLK	CP/RL $\bar{2}$	TR2	MODE
0	0	1	16-bit Auto-reload
0	1	1	16-bit Capture
1	X	1	Baud Rate Generator
X	X	0	Off

Low voltage 8-bit microcontrollers with UART and I²C-bus

P83CL781; P83CL782

12 REDUCED POWER MODES

There are two software-selectable modes which further reduce power consumption: 'Idle' and 'Power-down'.

12.1 Idle mode

Operation in Idle mode permits the interrupt, serial ports and timer blocks to continue to function while the clock to the CPU is halted.

Idle mode is entered by setting the IDL bit in the Power Control Register (PCON.0, see Table 5). The instruction that sets IDL is the last instruction executed in the normal operating mode before the Idle mode is activated.

Once in the Idle mode, the CPU status is preserved along with the Stack Pointer, Program Counter, Program Status Word and Accumulator. The RAM and all other registers maintain their data during Idle mode. The status of the external pins during Idle mode is shown in Table 4.

The following functions remain active during the Idle mode:

- Timer 0, Timer 1 and Timer 2
- UART, I²C-bus interface
- External interrupt.

These functions may generate an interrupt or reset; thus ending the Idle mode.

There are two ways to terminate the Idle mode:

1. Activation of any enabled interrupt will cause PCON.0 to be cleared by hardware thus terminating the Idle mode. The interrupt is serviced, and following the RETI instruction, the next instruction to be executed will be the one following the instruction that put the device in the Idle mode. The flag bits GF0 and GF1 may be used to determine whether the interrupt was received during normal execution or during the Idle mode. For example, the instruction that writes to PCON.0 can also set or clear one or both flag bits. When the Idle mode is terminated by an interrupt, the service routine can examine the status of the flag bits.
2. The second way of terminating the Idle mode is with an external hardware reset, or an internal reset caused by an overflow of Timer T2. Since the oscillator is still running, the hardware reset is required to be active for two machine cycles (24 oscillator periods) to complete the reset operation. Reset redefines all SFRs but does not affect the on-chip RAM.

12.2 Power-down mode

Operation in Power-down mode freezes the oscillator. The internal connections which link both Idle and Power-down signals to the clock generation circuit are shown in Fig.12.

Power-down mode is entered by setting the PD bit in the Power Control Register (PCON.1, see Table 5). The instruction that sets PD is the last executed prior to going into the Power-down mode.

Once in the Power-down mode, the oscillator is stopped. The contents of the on-chip RAM and the SFRs are preserved. The port pins output the value held by their respective SFRs. ALE and PSEN are held LOW.

In the Power-down mode, V_{DD} may be reduced to minimize circuit power consumption. The supply voltage must not be reduced until the Power-down mode is entered, and must be restored before the hardware reset is applied which will free the oscillator. Reset should not be released until the oscillator has restarted and stabilized.

12.3 Wake-up from Power-down mode

When in Power-down mode the controller can be woken-up with either the external interrupts INT2 to INT9, or a reset operation. The wake-up operation has two basic approaches as explained in Section 12.3.1; 12.3.2 and illustrated in Fig.13.

12.3.1 WAKE-UP USING INT2 TO INT9

If any of the interrupts INT2 to INT9 are enabled, the device can be woken-up from the Power-down mode with the external interrupts. To ensure that the oscillator is stable before the controller restarts, the internal clock will remain inactive for 1536 oscillator periods. This is controlled by an on-chip delay counter.

12.3.2 WAKE-UP USING RST

To wake-up the P83CL78x, the RST pin must be kept HIGH for a minimum of 24 periods. The on-chip delay counter is inactive. The user must ensure that the oscillator is stable before any operation is attempted.

Low voltage 8-bit microcontrollers with UART and I²C-bus

P83CL781; P83CL782

12.4 Status of external pins

The status of the external pins during Idle and Power-down mode is shown in Table 4. If the Power-down mode is activated whilst accessing external Program Memory, the port data that is held in the Special Function Register P2 is restored to Port 2.

If the data is a logic 1, the port pin is held HIGH during the Power-down mode by the strong pull-up transistor 'p1'; see Fig.9(a).

Table 4 Status of external pins during Idle and Power-down modes

MODE	MEMORY	ALE	$\overline{\text{PSEN}}$	PORT 0	PORT 1	PORT 2	PORT 3
Idle	internal	1	1	port data	port data	port data	port data
Idle	external	1	1	floating	port data	address	port data
Power-down	internal	0	0	port data	port data	port data	port data
Power-down	external	0	0	floating	port data	port data	port data

12.5 Power Control Register (PCON)

The reduced power modes are activated by software using this Special Function Register. PCON is not bit addressable.

Table 5 Power Control Register (SFR address 87H)

7	6	5	4	3	2	1	0
SMOD	–	–	–	GF1	GF0	PD	IDL

Table 6 Description of PCON bits

BIT	SYMBOL	FUNCTION
PCON.7	SMOD	Double Baud rate bit. When set to a logic 1 the baud rate is doubled when the serial port SIO0 is being used in modes 1, 2 or 3.
PCON.6	–	Reserved
PCON.5	–	Reserved
PCON.4	–	Reserved
PCON.3	GF1	General purpose flag bit
PCON.2	GF0	General purpose flag bit
PCON.1	PD	Power-down bit. Setting this bit activates the Power-down mode; see note 1.
PCON.0	IDL	Idle mode bit. Setting this bit activates the Idle mode; see note 1.

Note

1. If logic 1s are written to PD and IDL at the same time, PD takes precedence. The reset value of PCON is (0XX00000).

Low voltage 8-bit microcontrollers with
UART and I²C-bus

P83CL781; P83CL782

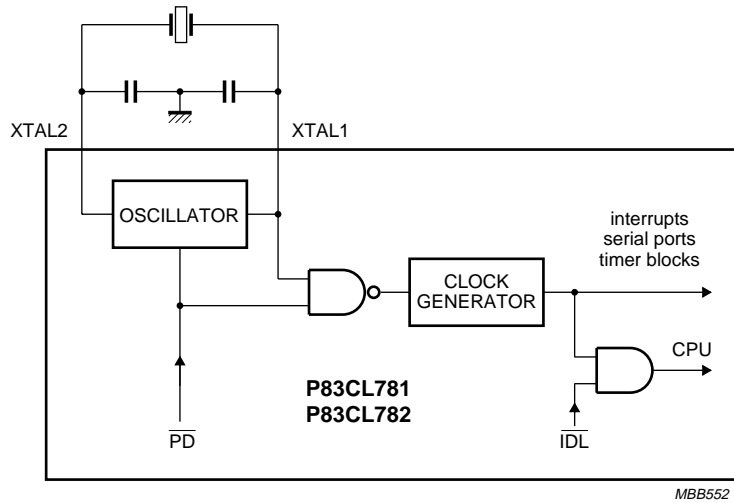

Fig.12 Internal clock control in Idle and Power-down modes.

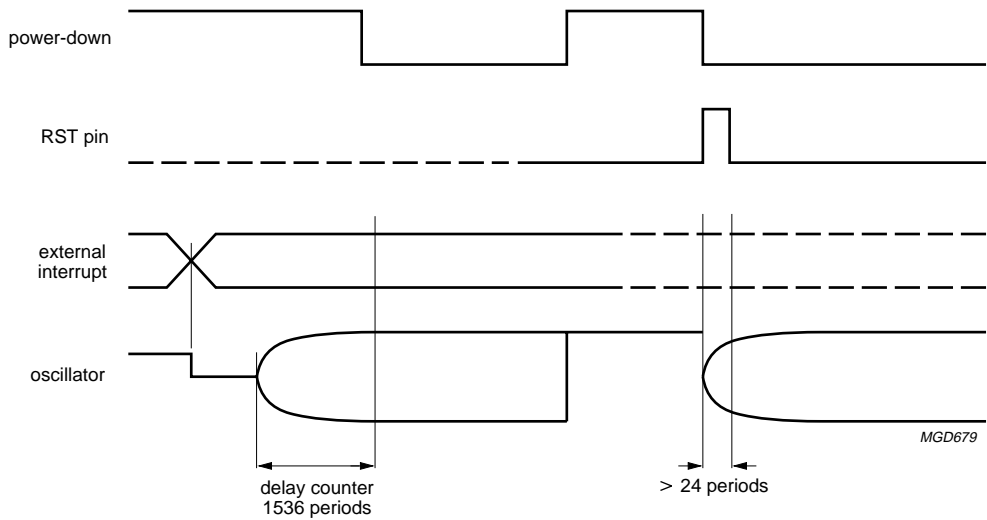

Fig.13 Wake-up operation.

Low voltage 8-bit microcontrollers with UART and I²C-bus

P83CL781; P83CL782

13 I²C-BUS SERIAL I/O

The serial port supports the twin line I²C-bus, which consists of a serial data line (SDA) and a serial clock line (SCL). These lines also function as the I/O port lines P1.7 and P1.6 respectively.

The system is unique because data transport, clock generation, address recognition and bus control arbitration are all controlled by hardware.

The I²C-bus serial I/O has complete autonomy in byte handling and operates in 4 modes:

- Master transmitter
- Master receiver
- Slave transmitter
- Slave receiver.

These functions are controlled by the Serial Control Register S1CON. S1STA is the Status Register whose contents may also be used as a vector to various service routines. S1DAT is the Data Shift Register and S1ADR is the Slave Address Register. Slave address recognition is performed by on-chip hardware.

Figure 14 is the block diagram of the I²C-bus serial I/O.

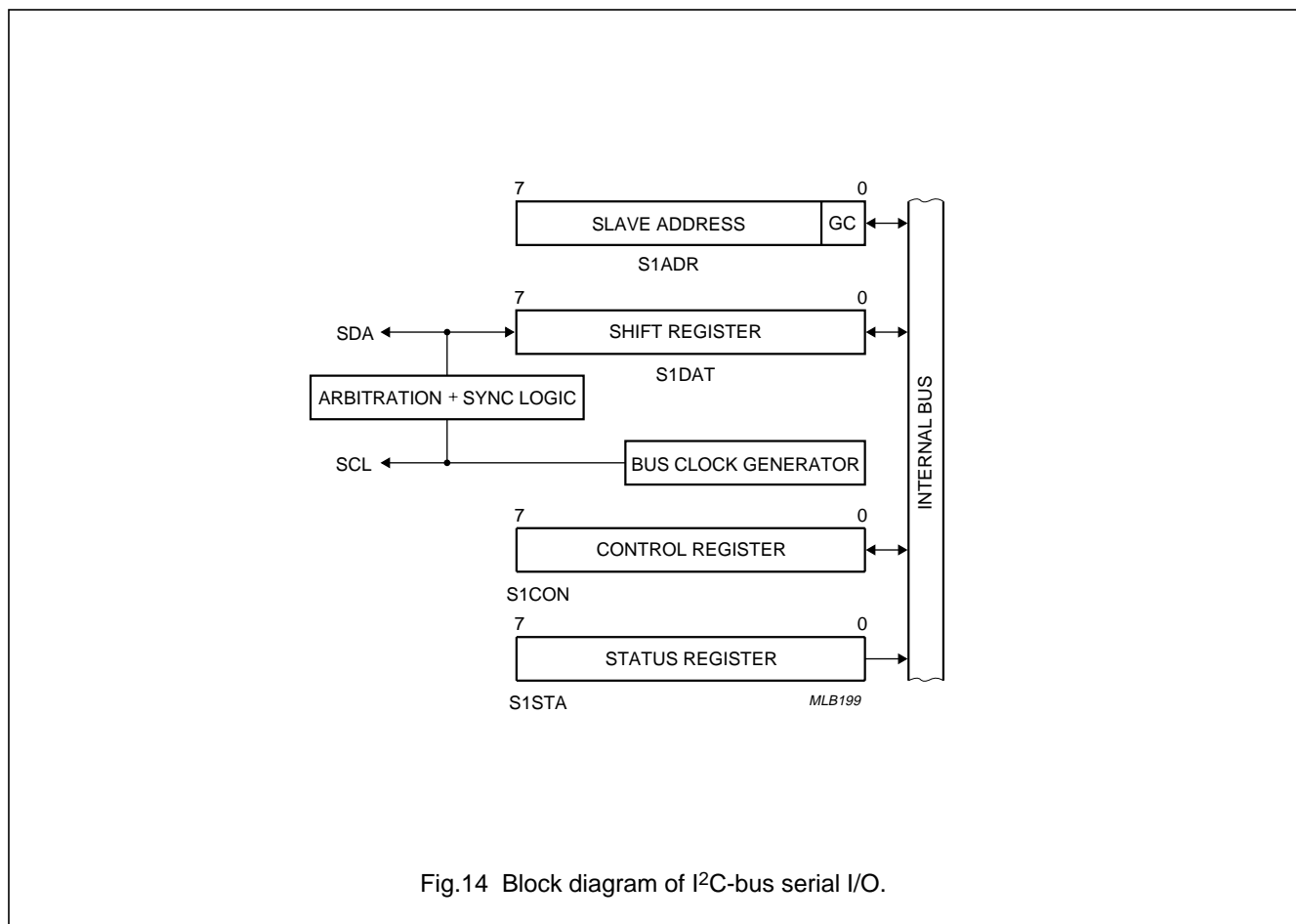

Fig.14 Block diagram of I²C-bus serial I/O.

Low voltage 8-bit microcontrollers with UART and I²C-bus

P83CL781; P83CL782

13.1 Serial Control Register (S1CON)

Table 7 Serial Control Register (SFR address D8H)

7	6	5	4	3	2	1	0
CR2	ENS1	STA	STO	SI	AA	CR1	CR0

Table 8 Description of S1CON bits

BIT	SYMBOL	DESCRIPTION
7	CR2	This bit along with bits CR1 (S1CON.1) and CR0 (S1CON.0) determines the serial clock frequency when SIO is in the Master mode. See Table 9.
6	ENS1	ENABLE serial I/O. When ENS1 = 0, the serial I/O is disabled. SDA and SCL outputs are in the high impedance state; P1.6 and P1.7 function as open-drain ports. When ENS1 = 1, the serial I/O is enabled. Output port latches P1.6 and P1.7 must be set to logic 1.
5	STA	START flag. When this bit is set in Slave mode, the SIO hardware checks the status of the I ² C-bus and generates a START condition if the bus is free or after the bus becomes free. If STA is set while the SIO is in Master mode, SIO will generate a repeated START condition.
4	STO	STOP flag. With this bit set while in Master mode a STOP condition is generated. When a STOP condition is detected on the I ² C-bus, the SIO hardware clears the STO flag. STO may also be set in Slave mode in order to recover from an error condition. In this case no STOP condition is transmitted to the I ² C-bus. However, the SIO hardware behaves as if a STOP condition has been received and releases the SDA and SCL. The SIO then switches to the not addressed slave receiver mode. The STOP flag is cleared by the hardware.
3	SI	SIO interrupt flag. This flag is set, and an interrupt is generated, after any of the following events occur: <ul style="list-style-type: none"> • A start condition is generated in Master mode • Own slave address has been received during AA = 1 • The general call address has been received while GC (S1ADR.0) = 1 and AA = 1 • A data byte has been received or transmitted in Master mode (even if arbitration is lost) • A data byte has been received or transmitted as selected slave • A Stop or Start condition is received as selected slave receiver or transmitter.
2	AA	Assert Acknowledge. When this bit is set, an acknowledge (low level to SDA) is returned during the acknowledge clock pulse on the SCL line when: <ul style="list-style-type: none"> • Own slave address is received • General call address is received; GC (S1ADR.0) = 1 • A data byte is received while the device is programmed to be a Master Receiver • A data byte is received while the device is a selected Slave Receiver. When this bit is reset, no acknowledge is returned. Consequently, no interrupt is requested when the own slave address or general call address is received.
1	CR1	These two bits along with the CR2 (S1CON.7) bit determine the serial clock frequency when SIO is in the Master mode. See Table 9.
0	CR0	

Low voltage 8-bit microcontrollers with UART and I²C-bus

P83CL781; P83CL782

Table 9 Selection of the serial clock frequency SCL in a Master mode of operation

CR2	CR1	CR0	f _{osc} DIVISOR	BIT RATE (kHz) AT f _{osc}		
				3.58 MHz	6 MHz	12 MHz
0	0	0	256	14.0	23.4	46.9
0	0	1	224	16.0	26.8	53.6
0	1	0	192	18.6	31.3	62.5
0	1	1	160	22.4	37.5	75.0
1	0	0	960	3.73	6.25	12.5
1	0	1	120	29.8	50.0	100.0
1	1	0	60	59.7	100.0	–
1	1	1	not allowed	–	–	–

13.2 Serial Status Register (S1STA)

S1STA is a read-only register. The contents of this register may be used as a vector to a service routine. This optimizes the response time of the software and consequently that of the I²C-bus. The status codes for all possible modes of the I²C-bus interface are given in Tables 12 to 16.

Table 10 Serial Status Register (address D9H)

7	6	5	4	3	2	1	0
SC4	SC3	SC2	SC1	SC0	0	0	0

Table 11 Description of S1STA bits

BIT	SYMBOL	DESCRIPTION
3 to 7	SC4 to SC0	5-bit status code.
0 to 2	–	These three bits are always zero.

Table 12 MST/TRX mode

S1STA VALUE	DESCRIPTION
08H	A START condition has been transmitted.
10H	A repeated START condition has been transmitted.
18H	SLA and W have been transmitted, ACK has been received.
20H	SLA and W have been transmitted, $\overline{\text{ACK}}$ received.
28H	DATA of S1DAT has been transmitted, ACK received.
30H	DATA of S1DAT has been transmitted, $\overline{\text{ACK}}$ received.
38H	Arbitration lost in SLA, R/W or DATA.

Low voltage 8-bit microcontrollers with UART and I²C-bus

P83CL781; P83CL782

Table 13 MST/REC mode

S1STA VALUE	DESCRIPTION
08H	A START condition has been transmitted.
10H	A repeated START condition has been transmitted.
38H	Arbitration lost while returning $\overline{\text{ACK}}$.
40H	SLA and R have been transmitted, ACK received.
48H	SLA and R have been transmitted, $\overline{\text{ACK}}$ received.
50H	DATA has been received, ACK returned.
58H	DATA has been received, $\overline{\text{ACK}}$ returned.

Table 14 SLV/REC mode

S1STA VALUE	DESCRIPTION
60H	Own SLA and W have been received, ACK returned.
68H	Arbitration lost in SLA, R/W as MST. Own SLA and W have been received, ACK returned.
70H	General CALL has been received, ACK returned.
78H	Arbitration lost in SLA, R/W as MST. General CALL has been received.
80H	Previously addressed with own SLA. DATA byte received, ACK returned.
88H	Previously addressed with own SLA. DATA byte received, $\overline{\text{ACK}}$ returned.
90H	Previously addressed with general CALL. DATA byte has been received, ACK has been returned.
98H	Previously addressed with general CALL. DATA byte has been received, $\overline{\text{ACK}}$ has been returned.
A0H	A STOP condition or repeated START condition has been received while still addressed as SLV/REC or SLV/TRX.

Table 15 SLV/TRX mode

S1STA VALUE	DESCRIPTION
A8H	Own SLA and R have been received, ACK returned.
B0H	Arbitration lost in SLA, R/W as MST. Own SLA and R have been received, ACK returned.
B8H	DATA byte has been transmitted, ACK received.
C0H	DATA byte has been transmitted, $\overline{\text{ACK}}$ received.
C8H	Last DATA byte has been transmitted (AA = 0), ACK received.

Table 16 Miscellaneous

S1STA VALUE	DESCRIPTION
00H	Bus error during MST mode or selected SLV mode, due to an erroneous START or STOP condition.
F8H	No relevant state information available, SI = 0.

Low voltage 8-bit microcontrollers with UART and I²C-bus

P83CL781; P83CL782

Table 17 Symbols used in Tables 12 to 16

SYMBOL	DESCRIPTION
SLA	7-bit slave address
R	Read bit
W	Write bit
ACK	Acknowledgement (acknowledge bit is logic 0)
$\overline{\text{ACK}}$	No acknowledgement (acknowledge bit is logic 1)
DATA	8-bit data byte to or from I ² C-bus
MST	Master
SLV	Slave
TRX	Transmitter
REC	Receiver

13.3 Data Shift Register (S1DAT)

S1DAT contains the serial data to be transmitted or data which has just been received. The MSB (bit 7) is transmitted or received first; i.e. data shifted from right to left.

Table 18 Data Shift Register (SFR address DAH)

7	6	5	4	3	2	1	0
S1DAT.7	S1DAT.6	S1DAT.5	S1DAT.4	S1DAT.3	S1DAT.2	S1DAT.1	S1DAT.0

13.4 Address Register (S1ADR)

This 8-bit register may be loaded with the 7-bit slave address to which the controller will respond when programmed as a slave receiver/transmitter.

Table 19 Address Register (SFR address DBH)

7	6	5	4	3	2	1	0
SLA6	SLA5	SLA4	SLA3	SLA2	SLA1	SLA0	GC

Table 20 Description of S1ADR bits

BIT	SYMBOL	DESCRIPTION
7 to 1	SLA6 to SLA0	Own slave address.
0	GC	This bit is used to determine whether the general call address is recognized. When GC = 0, the general call address is not recognized; when GC = 1, the general call address is recognized.

Low voltage 8-bit microcontrollers with UART and I²C-bus

P83CL781; P83CL782

14 STANDARD SERIAL INTERFACE SIO0: UART

This serial port is full duplex which means that it can transmit and receive simultaneously. It is also receive-buffered and can commence reception of a second byte before a previously received byte has been read from the register. (However, if the first byte has not been read by the time the reception of the second byte is complete, one of the bytes will be lost). The serial port receive and transmit registers are both accessed via the Special Function Register S0BUF. Writing to S0BUF loads the transmit register and reading S0BUF accesses a physically separate receive register.

The serial port can operate in 4 modes:

- Mode 0 Serial data enters and exits through RXD. TXD outputs the shift clock. Eight bits are transmitted/received (LSB first). The baud rate is fixed at $\frac{1}{12} \times f_{osc}$.
- Mode 1 10 bits are transmitted (through TXD) or received (through RXD): a start bit (logic 0), 8 data bits (LSB first), and a stop bit (logic 1). On receive, the stop bit goes into RB8 in Special Function Register S0CON. The baud rate is variable.
- Mode 2 11 bits are transmitted (through TXD) or received (through RXD): start bit (logic 0), 8 data bits (LSB first), a programmable 9th data bit, and a stop bit (logic 1). On transmit, the 9th data bit (TB8 in S0CON) can be assigned the value of a logic 0 or logic 1. Or, for example, the parity bit (P, in the PSW) could be moved into TB8. On receive, the 9th data bit goes into RB8 in S0CON, while the stop bit is ignored. The baud rate is programmable to either $\frac{1}{32}$ or $\frac{1}{64} \times f_{osc}$.
- Mode 3 11 bits are transmitted (through TXD) or received (through RXD): a start bit (logic 0), 8 data bits (LSB first), a programmable 9th data bit and a stop bit (logic 1). In fact, Mode 3 is the same as Mode 2 in all respects except baud rate. The baud rate in Mode 3 is variable.

In all four modes, transmission is initiated by any instruction that uses S0BUF as a destination register. Reception is initiated in Mode 0 by the condition RI = 0 and REN = 1. Reception is initiated in the other modes by the incoming start bit if REN = 1.

14.1 Multiprocessor communications

Modes 2 and 3 have a special provision for multiprocessor communications. In these modes, 9 data bits are received. The 9th bit goes into RB8. The following bit is the stop bit. The port can be programmed such that when the stop bit is received, the serial port interrupt will be activated, but only if RB8 = 1. This feature is enabled by setting bit SM2 in S0CON. One use of this feature, in multiprocessor systems, is as follows.

When the master processor wants to transmit a block of data to one of several slaves, it first sends out an address byte which identifies the target slave. An address byte differs from a data byte in that the 9th bit is HIGH in an address byte and LOW in a data byte. With SM2 = 1, no slave will be interrupted by a data byte. An address byte, however, will interrupt all slaves, so that each slave can examine the received byte and see if it is being addressed. The addressed slave will clear its SM2 bit and prepare to receive the data bytes that will be sent. The slaves that were not being addressed leave their SM2 bits set and go on about their business, ignoring the coming data bytes.

SM2 has no effect in Mode 0, and in Mode 1 can be used to check the validity of the stop bit. In a Mode 1 reception, if SM2 = 1, the receive interrupt will not be activated unless a valid stop bit is received.

Low voltage 8-bit microcontrollers with UART and I²C-bus

P83CL781; P83CL782

14.2 Serial Port Control and Status Register (S0CON)

The Serial Port Control and Status Register is the Special Function Register S0CON. The register contains not only the mode selection bits, but also the 9th data bit for transmit and receive (TB8 and RB8), and the serial port interrupt bits (TI and RI).

Table 21 Serial Port Control Register (address 98H)

7	6	5	4	3	2	1	0
SM0	SM1	SM2	REN	TB8	RB8	TI	RI

Table 22 Description of S0CON bits

BIT	SYMBOL	DESCRIPTION
7	SM0	These bits are used to select the serial port mode; see Table 23.
6	SM1	
5	SM2	Enables the multiprocessor communication feature in Modes 2 and 3. In these modes, if SM2 = 1, then RI will not be activated if the received 9 th data bit (RB8) is a logic 0. In Mode 1, if SM2 = 1, then RI will not be activated unless a valid stop bit was received. In Mode 0, SM2 should be a logic 0.
4	REN	Enables serial reception and is set by software to enable reception, and cleared by software to disable reception.
3	TB8	Is the 9 th data bit that will be transmitted in Modes 2 and 3. Set or cleared by software as desired.
2	RB8	In Modes 2 and 3, is the 9 th data bit received. In Mode 1, if SM2 = 0 then RB8 is the stop bit that was received. In Mode 0, RB8 is not used.
1	TI	The transmit interrupt flag. Set by hardware at the end of the 8 th bit time in Mode 0, or at the beginning of the stop bit time in the other modes, in any serial transmission. Must be cleared by software.
0	RI	The receive interrupt flag. Set by hardware at the end of the 8 th bit time in Mode 0, or halfway through the stop bit time in the other modes, in any serial transmission (except see SM2). Must be cleared by software.

Table 23 Selection of the serial port modes

SM0	SM1	MODE	DESCRIPTION	BAUD RATE
0	0	Mode 0	Shift register	$\frac{1}{12} \times f_{osc}$
0	1	Mode 1	8-bit UART	variable
1	0	Mode 2	9-bit UART	$\frac{1}{32}$ or $\frac{1}{64} \times f_{osc}$
1	1	Mode 3	9-bit UART	variable

Low voltage 8-bit microcontrollers with UART and I²C-bus

P83CL781; P83CL782

14.3 Baud rates

The baud rate in Mode 0 is fixed and may be calculated as:

$$\text{Baud Rate} = \frac{f_{\text{osc}}}{12}$$

The baud rate in Mode 2 depends on the value of the SMOD bit in Special Function Register PCON and may be calculated as:

$$\text{Baud Rate} = \frac{2^{\text{SMOD}}}{64} \times f_{\text{osc}}$$

- If SMOD = 0 (value on reset), the baud rate is $\frac{1}{64} \times f_{\text{osc}}$
- If SMOD = 1, the baud rate is $\frac{1}{32} \times f_{\text{osc}}$

The baud rates in Modes 1 and 3 are determined by the Timer 1 or Timer 2 overflow rate.

14.3.1 USING TIMER 1 TO GENERATE BAUD RATES

When Timer 1 is used as the Baud Rate Generator, the baud rates in Modes 1 and 3 are determined by the Timer 1 overflow rate and the value of the SMOD bit as follows:

$$\text{Baud Rate} = \frac{2^{\text{SMOD}}}{32} \times \text{Timer 1 Overflow Rate.}$$

The Timer 1 interrupt should be disabled in this application. The Timer itself can be configured for either 'timer' or 'counter' operation in any of its 3 running modes. In most typical applications, it is configured for 'timer' operation, in the Auto-reload mode (high nibble of TMOD = 0010B). In this case the baud rate is given by the formula:

$$\text{Baud Rate} = \frac{2^{\text{SMOD}}}{32} \times \frac{f_{\text{osc}}}{\{12 \times (256 - \text{TH1})\}}$$

By configuring Timer 1 to run as a 16-bit timer (high nibble of TMOD = 0001B), and using the Timer 1 interrupt to do a 16-bit software reload, very low baud rates can be achieved. Table 24 lists commonly used baud rates and how they can be obtained from Timer 1.

Table 24 Commonly used baud rates generated by Timer 1

BAUD RATE (kb/s)	f _{osc} (MHz)	SMOD	C/T	TIMER 1 MODE	RELOAD VALUE
1000.0 ⁽¹⁾	12.000	X ⁽²⁾	X	X	X
375.0 ⁽³⁾	12.000	1	X	X	X
62.5 ⁽⁴⁾	12.000	1	0	Mode 2	FFH
19.2	11.059	1	0	Mode 2	FDH
9.6	11.059	0	0	Mode 2	FDH
4.8	11.059	0	0	Mode 2	FAH
2.4	11.059	0	0	Mode 2	F4H
1.2	11.059	0	0	Mode 2	E8H
137.5	11.986	0	0	Mode 2	1DH
110.0	6.000	0	0	Mode 2	72H
110.0	12.000	0	0	Mode 1	FEEBH

Notes

1. Maximum in Mode 0.
2. X = don't care.
3. Maximum in Mode 2.
4. Maximum in Modes 1 and 3.

Low voltage 8-bit microcontrollers with UART and I²C-bus

P83CL781; P83CL782

14.3.2 USING TIMER 2 TO GENERATE BAUD RATES

Timer 2 is selected as a Baud Rate Generator by setting the RTCLK bit in T2CON. The Baud Rate Generator mode is similar to the Auto-reload mode, in that a roll-over in TH2 causes Timer 2 registers to be reloaded with the 16-bit value held in the registers RCAP2H and RCAP2L, which are preset by software. Baud rates in Modes 1 and 3 are determined by Timer 2's overflow rate as specified below.

$$\text{Baud Rate} = \frac{\text{Timer 2 Overflow Rate}}{16}$$

The Timer 2 can be configured for either 'timer' or 'counter' operation. In the most typical applications, it is configured for 'timer' operation (C/T2 = 0). 'Timer' operation is slightly different for Timer 2 when it is being used as a Baud Rate Generator. Normally, as a timer it would increment every machine cycle at a frequency of $\frac{1}{12} \times f_{osc}$. However, as a Baud Rate Generator it increments every state time at a frequency of $\frac{1}{2} \times f_{osc}$. In this case the baud rate in Modes 1 and 3 is determined as:

$$\text{Baud Rate} = \frac{f_{osc}}{32 \times \{65536 - (\text{RCAP2H}; \text{RCAP2L})\}}$$

Where (RCAP2H; RCAP2L) is the content of registers RCAP2H and RCAP2L taken as a 16-bit unsigned integer.

The Baud Rate Generator mode for Timer 2 is shown in Fig.15. This figure is only valid if RTCLK = 1. At roll-over TH2 does not set the TF2 bit in T2CON and therefore, will not generate an interrupt. Consequently, the Timer 2 interrupt does not need to be disabled when in the Baud Rate Generator mode. If EXEN2 is set, a HIGH-to-LOW transition on T2EX will set the EXF2 bit, also in T2CON, but will not cause a reload from (RCAP2H; RCAP2L) to (TH2, TL2). Therefore, in this mode T2EX may be used as an additional external interrupt.

When Timer 2 is operating as a timer (TR2 = 1), in the Baud Rate Generator mode, registers TH2 and TL2 should not be accessed (read or write). Under these conditions the timer is being incremented every state time and therefore the results of a read or write may not be accurate. The registers RCAP2H and RCAP2L however, may be read but not written to. A write might overlap a reload and cause write and/or reload errors. If a write operation is required, Timer 2 or RCAP2H/RCAP2L should first be turned off by clearing the TR2 bit.

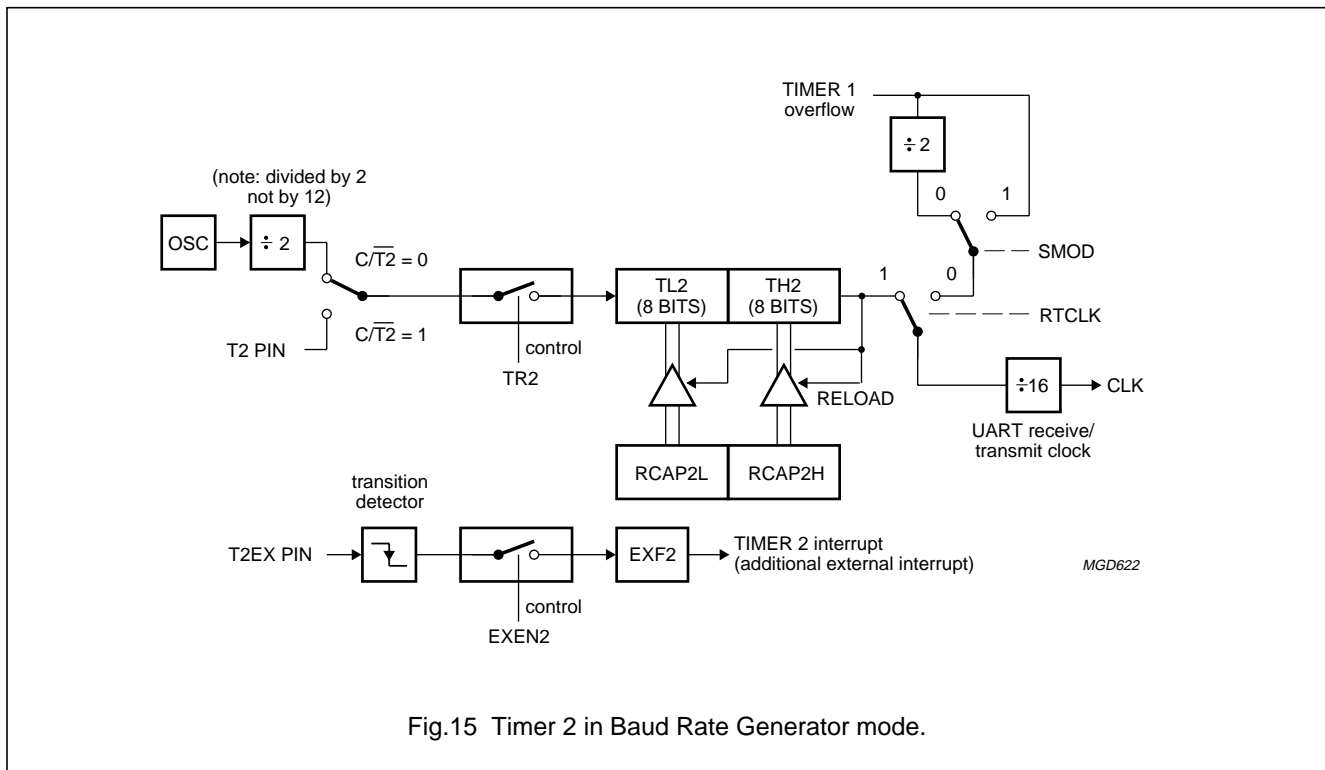

Fig.15 Timer 2 in Baud Rate Generator mode.

Low voltage 8-bit microcontrollers with
UART and I²C-bus

P83CL781; P83CL782

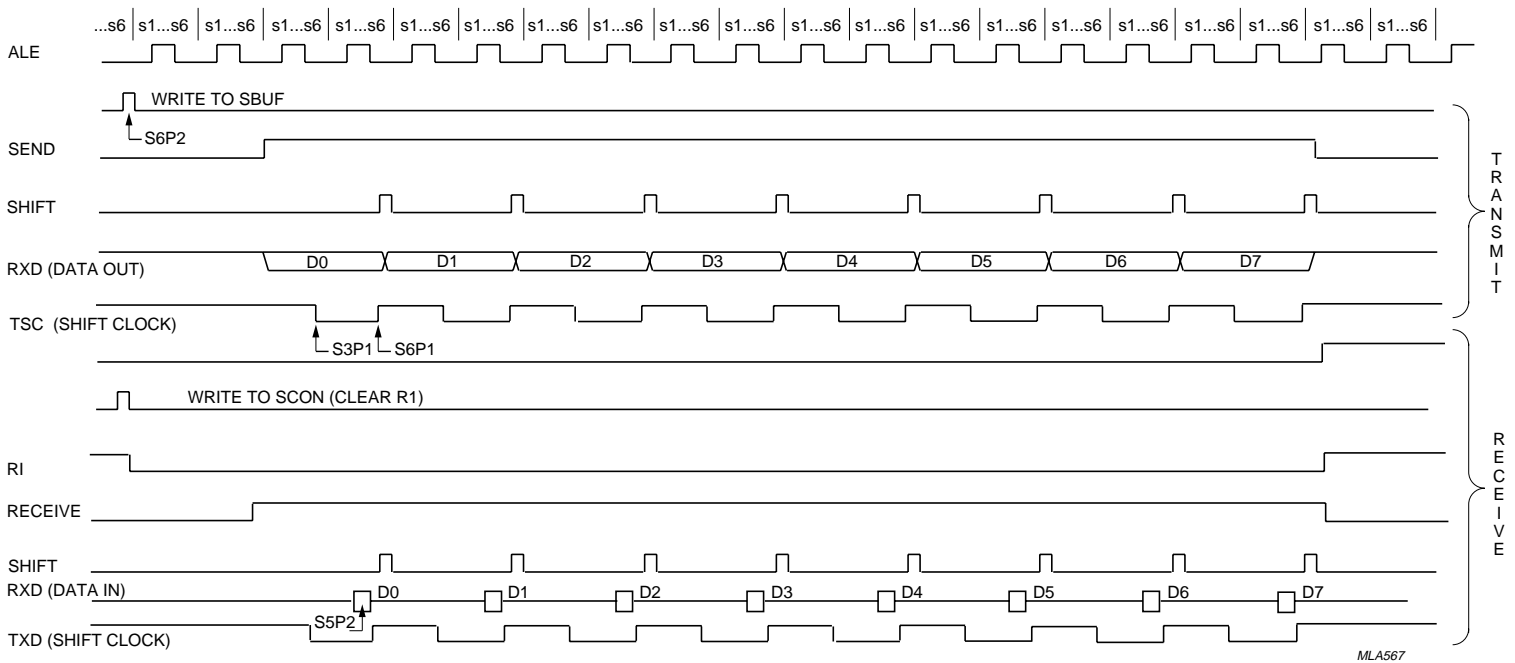
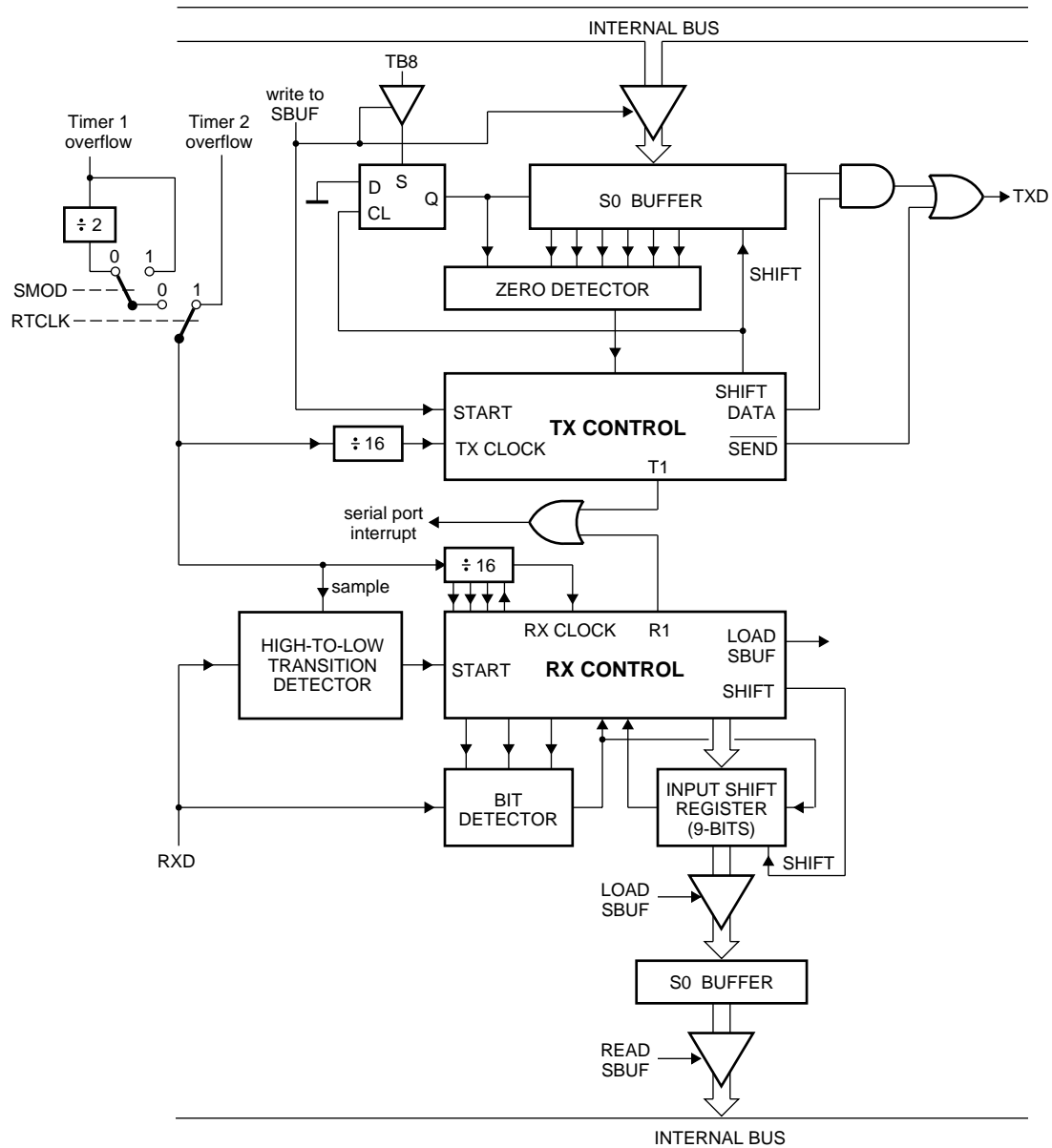

Fig.17 Serial port Mode 0 timing.

Low voltage 8-bit microcontrollers with
UART and I²C-bus

P83CL781; P83CL782



MGC755

Fig.18 Serial port Mode 1.

Low voltage 8-bit microcontrollers with
UART and I²C-bus

P83CL781; P83CL782

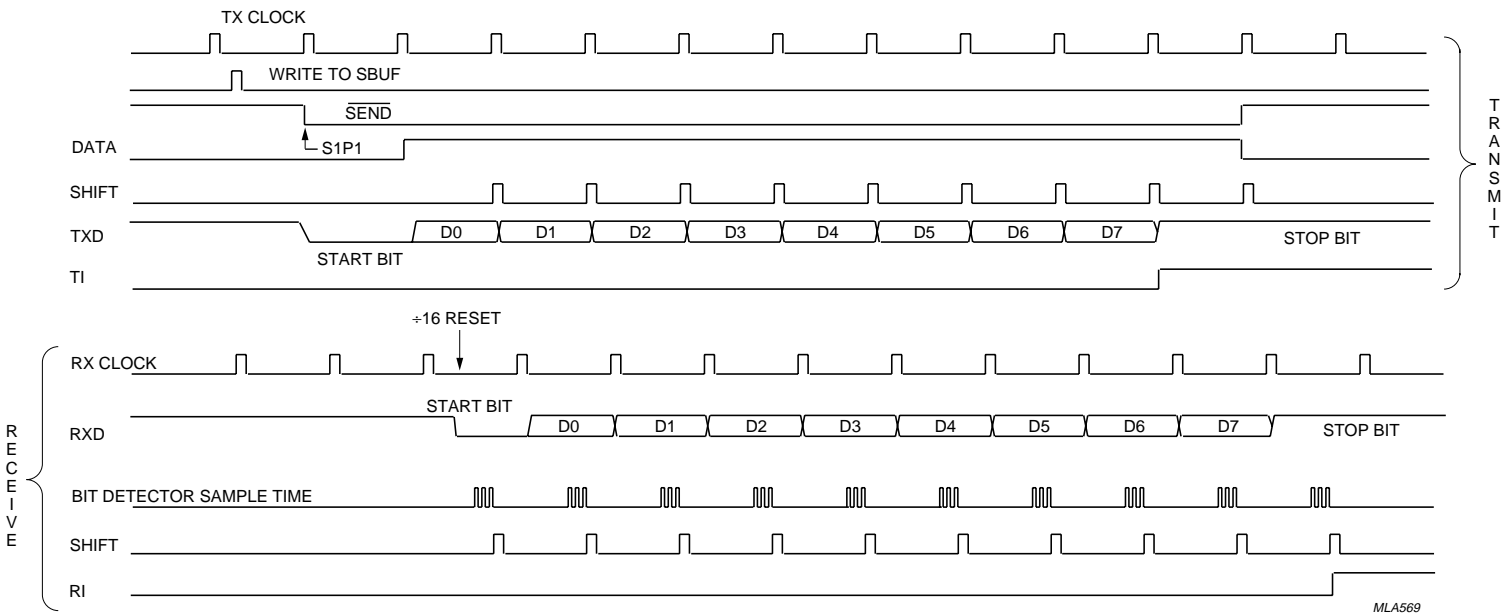
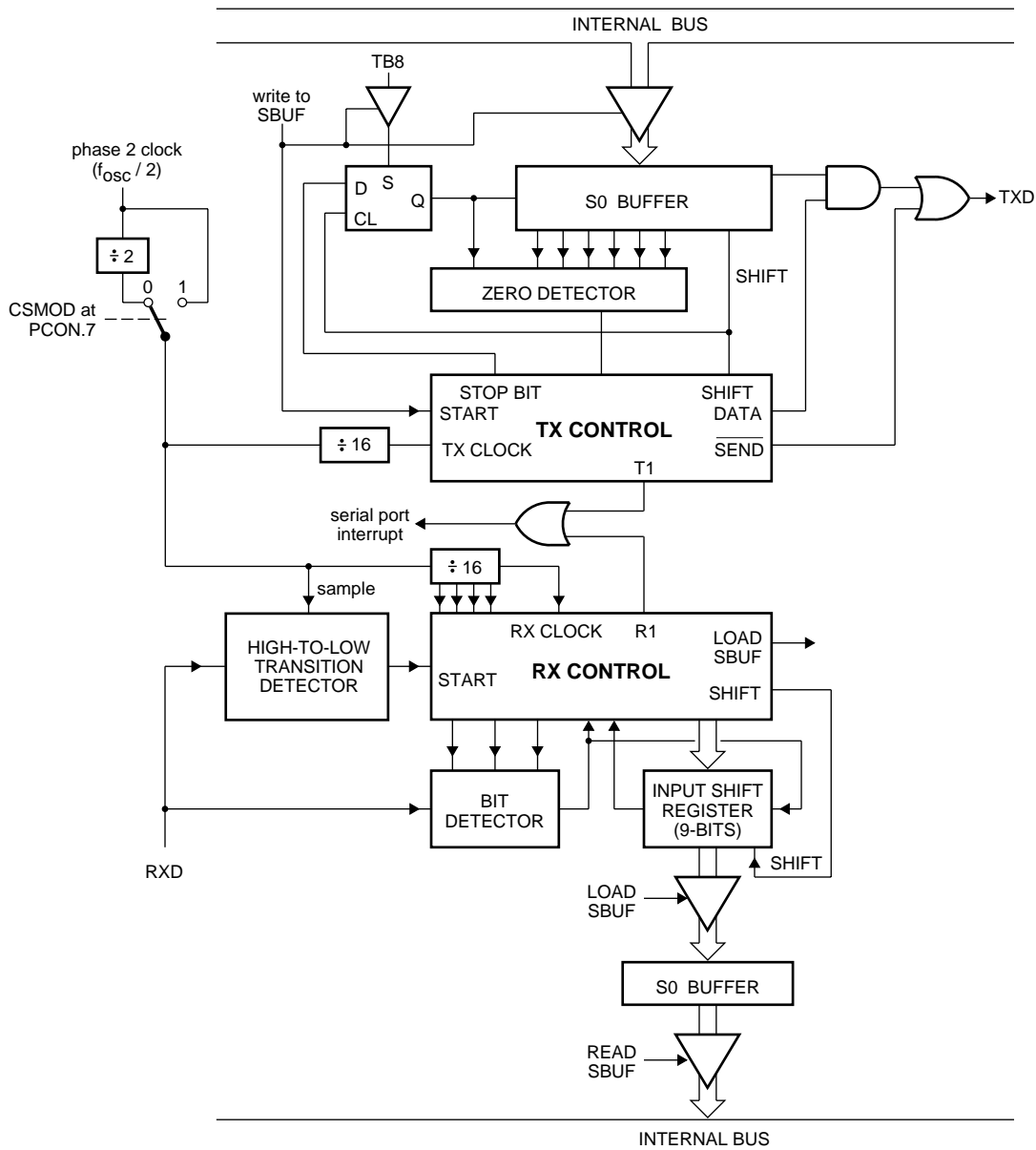

Fig.19 Serial port Mode 1 timing.

Low voltage 8-bit microcontrollers with
UART and I²C-bus

P83CL781; P83CL782



MGC754

Fig.20 Serial port Mode 2.

Low voltage 8-bit microcontrollers with UART and I²C-bus

P83CL781; P83CL782

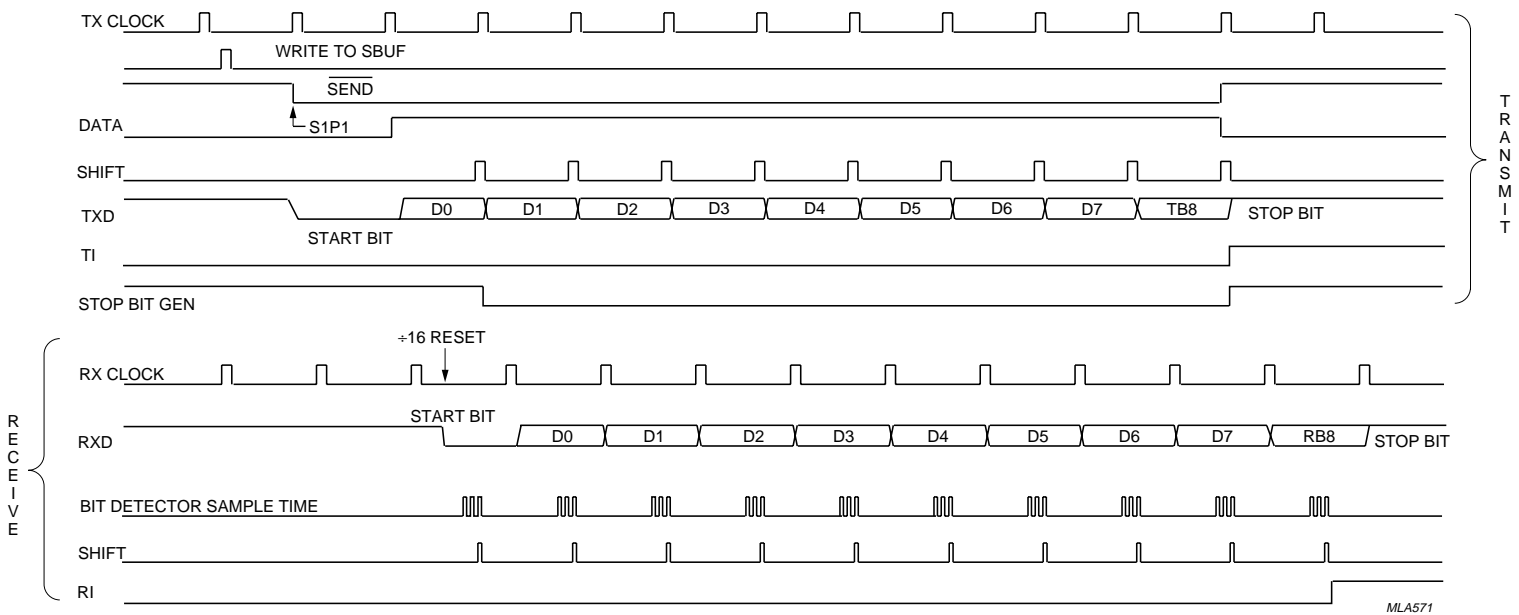
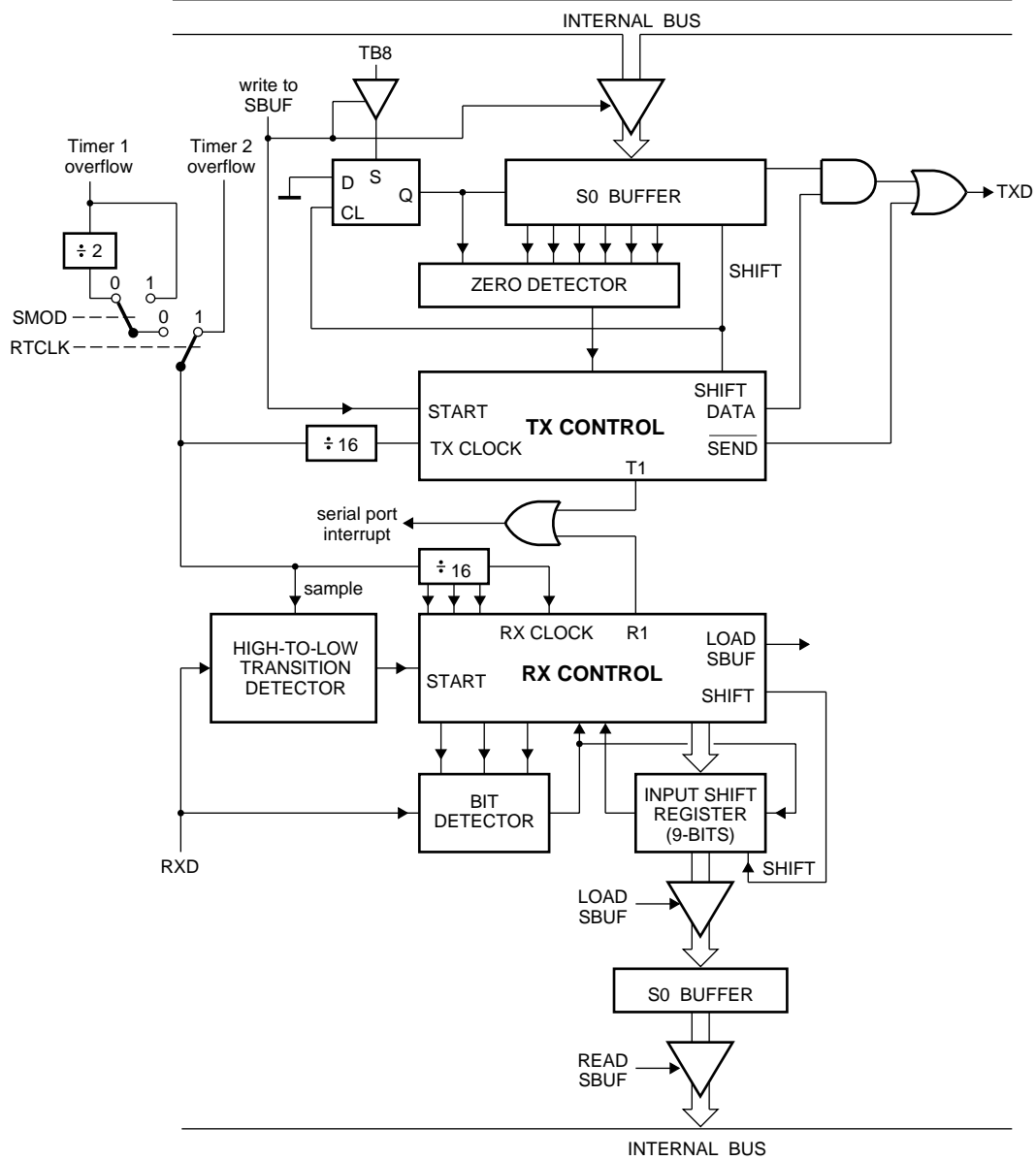

Fig.21 Serial port Mode 2 timing.

Low voltage 8-bit microcontrollers with
UART and I²C-bus

P83CL781; P83CL782



MGC753

Fig.22 Serial port Mode 3.

Low voltage 8-bit microcontrollers with
UART and I²C-bus

P83CL781; P83CL782

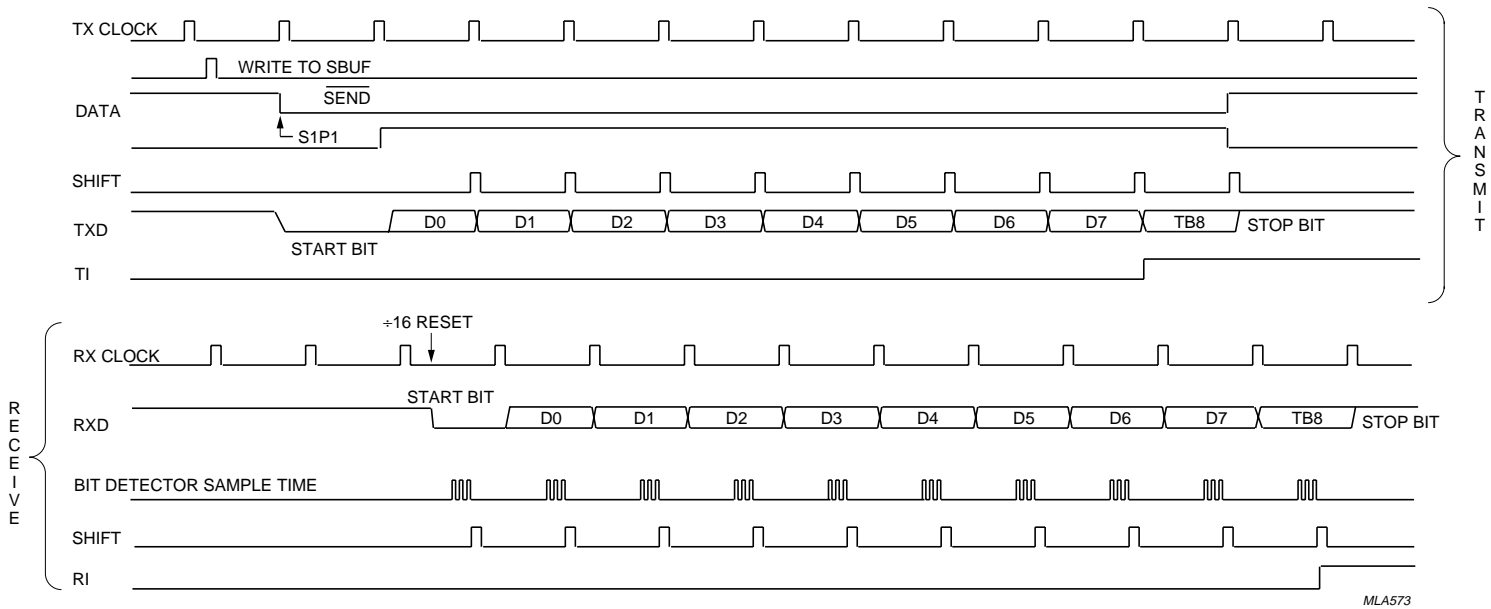

Fig.23 Serial port Mode 3 timing.

Low voltage 8-bit microcontrollers with UART and I²C-bus

P83CL781; P83CL782

15 INTERRUPT SYSTEM

External events and the real-time-driven on-chip peripherals require service by the CPU at unpredictable times. To tie the asynchronous activities of these functions to normal program execution a multiple-source, two-priority-level, nested interrupt system is provided. The system is shown in Fig.24. The P83CL78x acknowledges interrupt requests from fifteen sources as follows:

- INT0 to INT9
- Timer 0, Timer 1 and Timer 2
- I²C-bus serial I/O
- UART.

Each interrupt vectors to a separate location in Program Memory for its service routine. Each source can be individually enabled or disabled by its corresponding bit in the Interrupt Enable Registers (IEN0 and IEN1). The priority level is selected via the Interrupt Priority Registers (IP0 and IP1). All enabled sources can be globally disabled or enabled.

15.1 External interrupts INT2 to INT9

Port 1 lines serve an alternative purpose as eight additional interrupts INT2 to INT9. When enabled, each of these lines may wake-up the device from the Power-down mode. Using the Interrupt Polarity Register (IX1), each pin may be initialized to be either active HIGH or active LOW. IRQ1 is the Interrupt Request Flag Register. If the interrupt is enabled, each flag will be set on an interrupt request but must be cleared by software, i.e. via the interrupt software or when the interrupt is disabled.

Port 1 interrupts are level-sensitive. A Port 1 interrupt will be recognized when a level (HIGH or LOW depending on the Interrupt Polarity Register) on P1.n is held active for at least one machine cycle. The interrupt request is not serviced until the next machine cycle. Figure 25 shows the external interrupt system.

15.2 Interrupt priority

Each interrupt source can be set to either a high priority or to a low priority. If a low priority interrupt is received simultaneously with a high priority interrupt, the high priority interrupt will be dealt with first.

If interrupts of the same priority are requested simultaneously, the processor will branch to the interrupt polled first, according to the sequence shown in Table 25 and in Fig.24. The 'vector address' is the ROM location where the appropriate interrupt service routine starts.

Table 25 Interrupt vector polling sequence

SYMBOL	VECTOR ADDRESS (HEX)	SOURCE
X0 (first)	0003	External 0
S1	002B	I ² C port
X5	0053	External 5
T0	000B	Timer 0
T2	0033	Timer 2
X6	005B	External 6
X1	0013	External 1
X2	003B	External 2
X7	0063	External 7
T1	001B	Timer 1
X3	0043	External 3
X8	006B	External 8
SO	0023	UART
X4	004B	External 4
X9 (last)	0073	External 9

A low priority interrupt routine can only be interrupted by a high priority interrupt. A high priority interrupt routine cannot be interrupted.

Low voltage 8-bit microcontrollers with
UART and I²C-bus

P83CL781; P83CL782

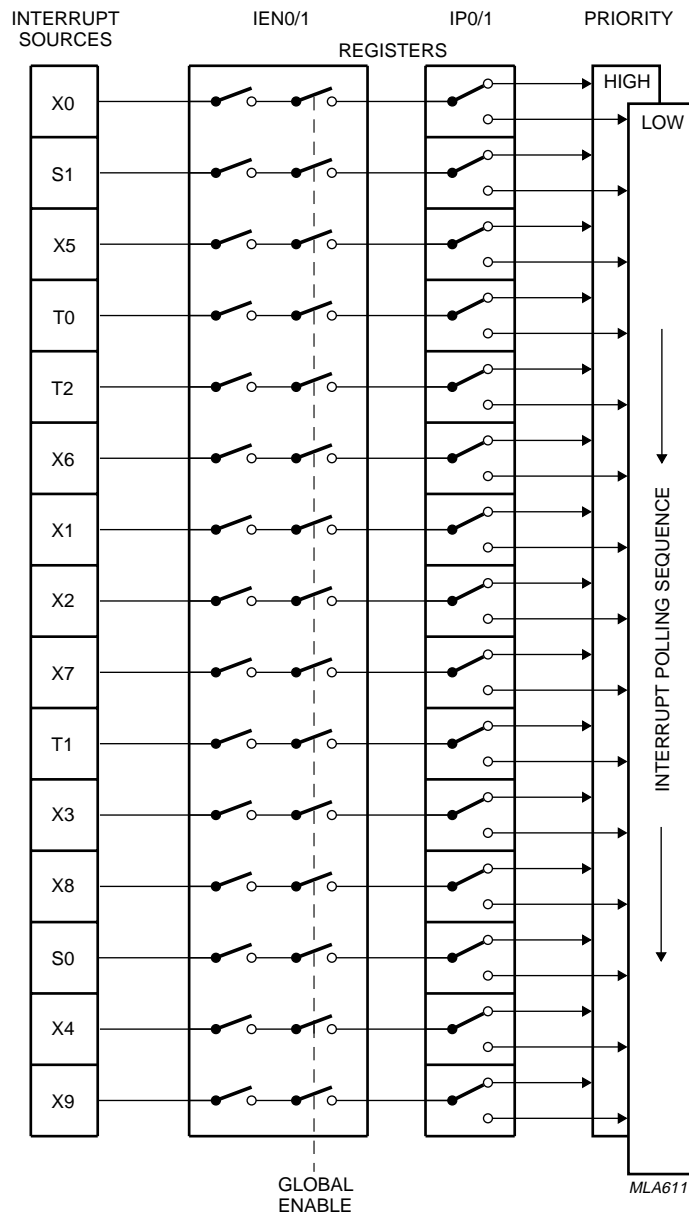
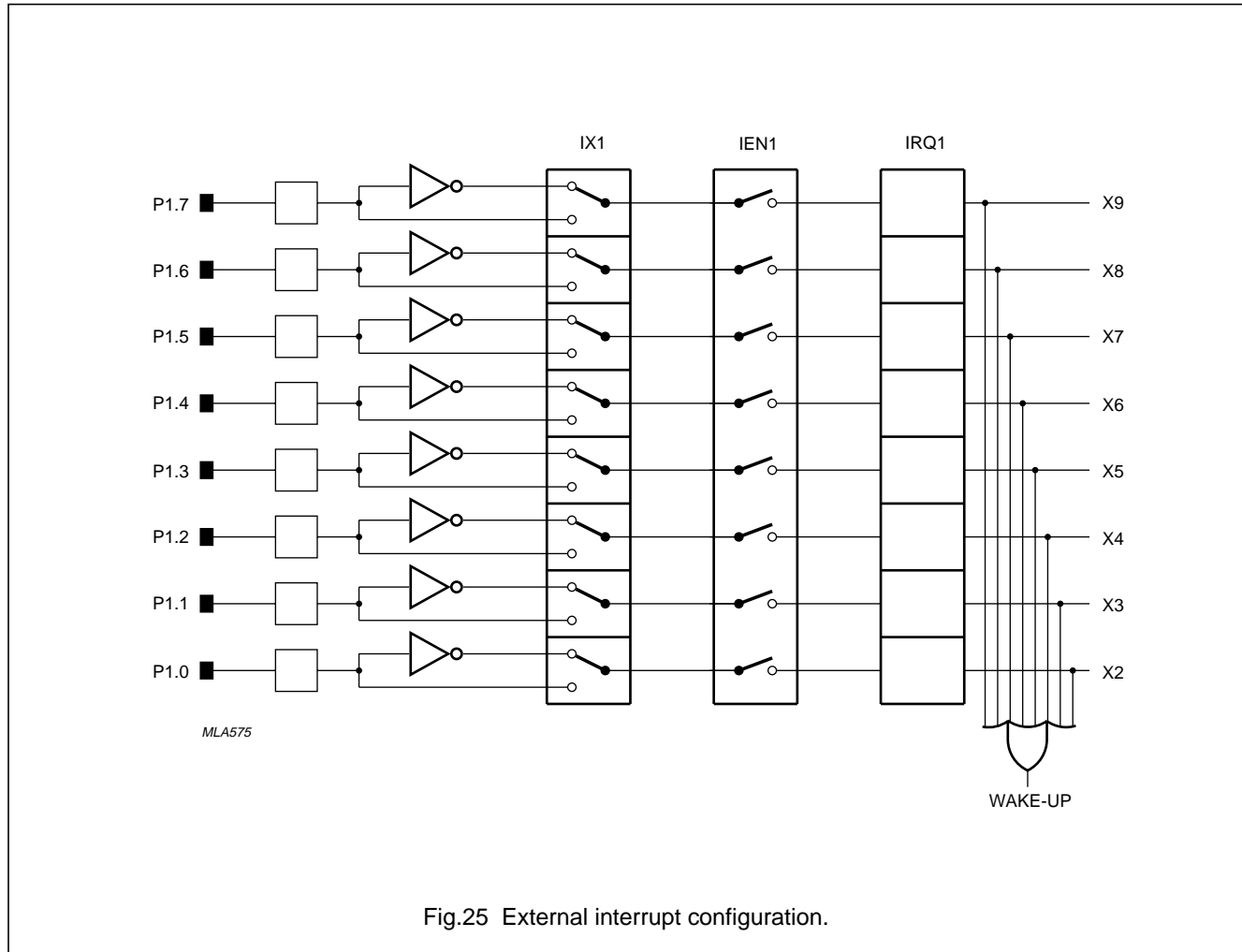

Fig.24 Interrupt system.

Low voltage 8-bit microcontrollers with
UART and I²C-bus

P83CL781; P83CL782



15.3 Interrupt registers

The registers used in the interrupt system are listed in Table 26. Tables 27 to 38 describe the contents of these registers.

Table 26 Special Function Registers related to the interrupt system

ADDRESS	REGISTER	DESCRIPTION
A8H	IEN0	Interrupt Enable Register
E8H	IEN1	Interrupt Enable Register (INT2 to INT9)
B8H	IPO	Interrupt Priority Register
F8H	IP1	Interrupt Priority Register (INT2 to INT9)
E9H	IX1	Interrupt Polarity Register
C0H	IRQ1	Interrupt Request Flag Register

Low voltage 8-bit microcontrollers with UART and I²C-bus

P83CL781; P83CL782

15.3.1 INTERRUPT ENABLE REGISTER (IEN0)

Bit values: 0 = interrupt disabled; 1 = interrupt enabled.

Table 27 Interrupt Enable Register (SFR address A8H)

7	6	5	4	3	2	1	0
EA	ET2	ES1	ES0	ET1	EX1	ET0	EX0

Table 28 Description of IEN0 bits

BIT	SYMBOL	DESCRIPTION
7	EA	General enable/disable control. If EA = 0, no interrupt is enabled. If EA = 1, any individually enabled interrupt will be accepted.
6	ET2	enable T2 interrupt
5	ES1	enable I ² C interrupt
4	ES0	enable UART SIO interrupt
3	ET1	enable Timer 1 interrupt (T1)
2	EX1	enable external interrupt 1
1	ET0	enable Timer 0 interrupt (T0)
0	EX0	enable external interrupt 0

15.3.2 INTERRUPT ENABLE REGISTER (IEN1)

Bit values: 0 = interrupt disabled; 1 = interrupt enabled.

Table 29 Interrupt Enable Register (SFR address E8H)

7	6	5	4	3	2	1	0
EX9	EX8	EX7	EX6	EX5	EX4	EX3	EX2

Table 30 Description of IEN1 bits

BIT	SYMBOL	DESCRIPTION
7	EX9	enable external interrupt 9
6	EX8	enable external interrupt 8
5	EX7	enable external interrupt 7
4	EX7	enable external interrupt 6
3	EX5	enable external interrupt 5
2	EX4	enable external interrupt 4
1	EX3	enable external interrupt 3
0	EX2	enable external interrupt 2

Low voltage 8-bit microcontrollers with UART and I²C-bus

P83CL781; P83CL782

15.3.3 INTERRUPT PRIORITY REGISTER (IP0)

Bit values: 0 = low priority; 1 = high priority.

Table 31 Interrupt Priority Register (SFR address B8H)

7	6	5	4	3	2	1	0
–	PT2	PS1	PS0	PT1	PX1	PT0	PX0

Table 32 Description of IP0 bits

BIT	SYMBOL	DESCRIPTION
7	–	reserved
6	PT2	Timer 2 interrupt priority level
5	PS1	I ² C interrupt priority level
4	PS0	UART SIO interrupt priority level
3	PT1	Timer 1 interrupt priority level
2	PX1	external interrupt 1 priority level
1	PT0	Timer 0 interrupt priority level
0	PX0	external interrupt 0 priority level

15.3.4 INTERRUPT PRIORITY REGISTER (IP1)

Bit values: 0 = low priority; 1 = high priority.

Table 33 Interrupt Priority Register (SFR address F8H)

7	6	5	4	3	2	1	0
PX9	PX8	PX7	PX6	PX5	PX4	PX3	PX2

Table 34 Description of IP1 bits

BIT	SYMBOL	DESCRIPTION
7	PX9	external interrupt 9 priority level
6	PX8	external interrupt 8 priority level
5	PX7	external interrupt 7 priority level
4	PX6	external interrupt 6 priority level
3	PX5	external interrupt 5 priority level
2	PX4	external interrupt 4 priority level
1	PX3	external interrupt 3 priority level
0	PX2	external interrupt 2 priority level

Low voltage 8-bit microcontrollers with UART and I²C-bus

P83CL781; P83CL782

15.3.5 INTERRUPT POLARITY REGISTER (IX1)

Writing either a logic 1 or logic 0 to any Interrupt Polarity Register bit sets the polarity level of the corresponding external interrupt to an active HIGH or active LOW respectively.

Table 35 Interrupt Polarity Register (SFR address E9H)

7	6	5	4	3	2	1	0
IL9	IL8	IL7	IL6	IL5	IL4	IL3	IL2

Table 36 Description of IX1 bits

BIT	SYMBOL	DESCRIPTION
7	IL9	external interrupt 9 polarity level
6	IL8	external interrupt 8 polarity level
5	IL7	external interrupt 7 polarity level
4	IL6	external interrupt 6 polarity level
3	IL5	external interrupt 5 polarity level
2	IL4	external interrupt 4 polarity level
1	IL3	external interrupt 3 polarity level
0	IL2	external interrupt 2 polarity level

15.3.6 INTERRUPT REQUEST FLAG REGISTER (IRQ1)

Table 37 Interrupt Request Flag Register (SFR address C0H)

7	6	5	4	3	2	1	0
IQ9	IQ8	IQ7	IQ6	IQ5	IQ4	IQ3	IQ2

Table 38 Description of IRQ1 bits

BIT	SYMBOL	DESCRIPTION
7	IQ9	external interrupt 9 request flag
6	IQ8	external interrupt 8 request flag
5	IQ7	external interrupt 7 request flag
4	IQ6	external interrupt 6 request flag
3	IQ5	external interrupt 5 request flag
2	IQ4	external interrupt 4 request flag
1	IQ3	external interrupt 3 request flag
0	IQ2	external interrupt 2 request flag

Low voltage 8-bit microcontrollers with UART and I²C-bus

P83CL781; P83CL782

16 OSCILLATOR CIRCUITRY

The on-chip oscillator circuitry of the P8xCL580 is a single-stage inverting amplifier biased by an internal feedback resistor. The oscillator circuit is shown in Fig.26. For operation as a standard quartz oscillator, no external components are needed, except for the 32 kHz option. When using external capacitors, ceramic resonators, coils and RC networks to drive the oscillator, five different configurations are supported (see Table 39 and Fig.26).

In the Power-down mode the oscillator is stopped and XTAL1 is pulled HIGH. The oscillator inverter is switched off to ensure no current will flow regardless of the voltage at XTAL1, for configurations (a), (b), (c), (d), (e) and (g) of Fig.26.

To drive the device with an external clock source, apply the external clock signal to XTAL1, and leave XTAL2 to float, as shown in Fig.26(f). There are no requirements on the duty cycle of the external clock, since the input to the internal clocking circuitry is buffered by a flip-flop.

Various oscillator options are provided for optimum on-chip oscillator performance; these are specified in Table 40 and shown in Fig.26. The required option should be stated when ordering.

Table 39 Oscillator options

OPTION	APPLICATION
Oscillator 1	For 32 kHz clock applications with external trimmer for frequency adjustment. A 4.7 MΩ bias resistor is needed for use in parallel with the crystal; see Fig.26(c).
Oscillator 2	Low-power, low-frequency operations using LC components; see Fig.26(e).
Oscillator 3	Medium frequency range applications.
Oscillator 4	High frequency range applications.
RC oscillator	RC oscillator configuration; see Figs 26(g) and 28.

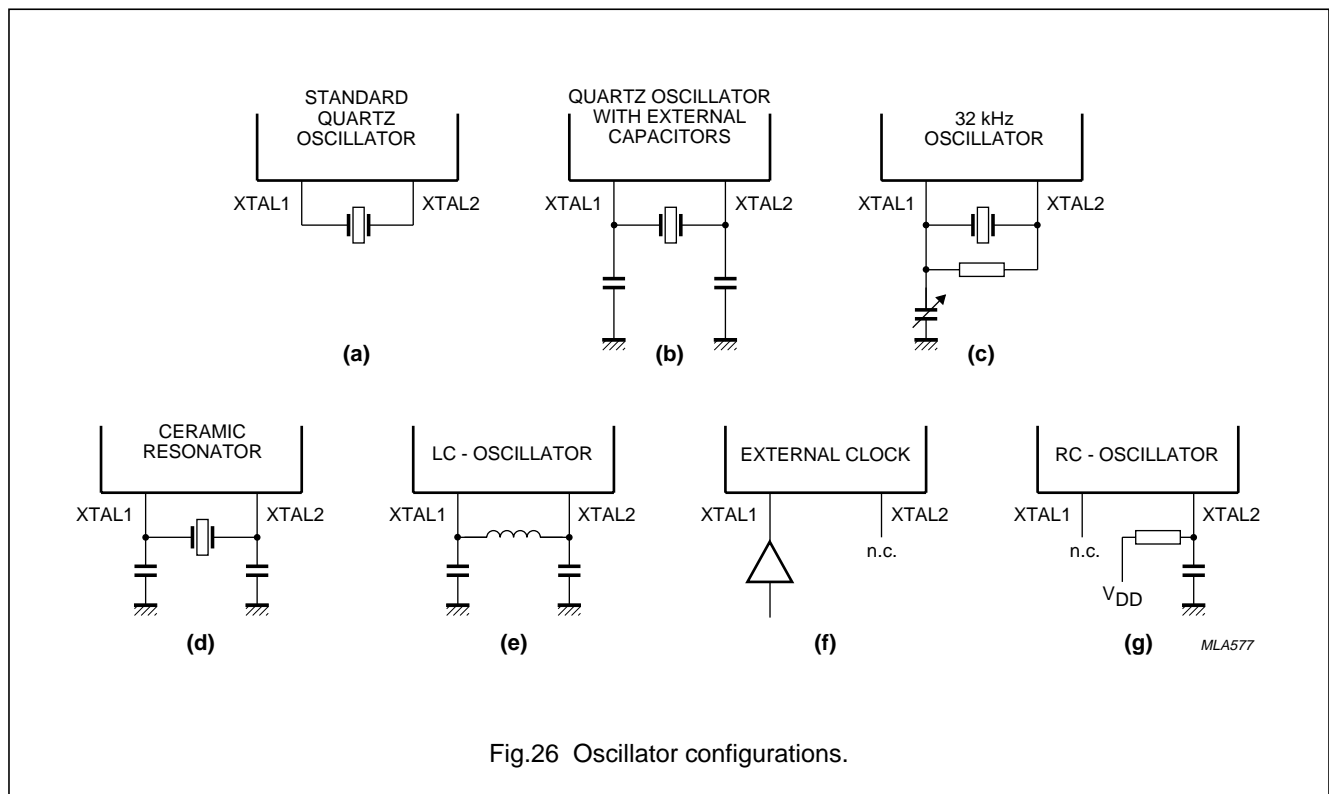

Fig.26 Oscillator configurations.

Low voltage 8-bit microcontrollers with
UART and I²C-bus

P83CL781; P83CL782

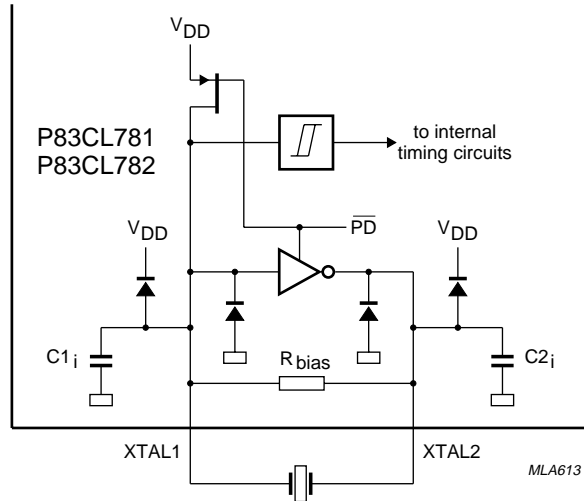
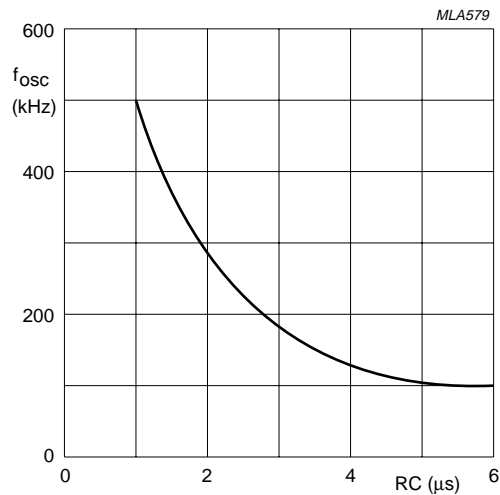

Fig.27 Standard oscillator.



RC oscillator frequency is externally adjustable; $100 \text{ kHz} \leq f_{osc} \leq 500 \text{ kHz}$.

Fig.28 RC oscillator; frequency as a function of RC.

Low voltage 8-bit microcontrollers with UART and I²C-bus

P83CL781; P83CL782

Table 40 Oscillator type selection guide

RESONATOR	FREQUENCY (MHz)	OPTION (see Table 39)	C1 EXT. (pF)		C2 EXT. (pF)		RESONATOR MAX. SERIES RESISTANCE
			MIN.	MAX.	MIN.	MAX.	
Quartz	0.032	Oscillator 1	0	0	5	15	15 k Ω ; note 1
	1.0	Oscillator 2	0	30	0	30	600 Ω
	3.58		0	15	0	15	100 Ω
	4.0		0	20	0	20	75 Ω
	6.0	Oscillator 3	0	10	0	10	60 Ω
	10.0	Oscillator 4	0	15	0	15	60 Ω
	12.0		0	10	0	10	40 Ω
	16.0		0	15	0	15	20 Ω
PXE	0.455	Oscillator 2	40	50	40	50	10 Ω
	1.0		15	50	15	50	100 Ω
	3.58		0	40	0	40	10 Ω
	4.0		0	40	0	40	10 Ω
	6.0		0	20	0	20	5 Ω
	10.0	Oscillator 3	0	15	0	15	6 Ω
	12.0	Oscillator 4	10	40	10	40	6 Ω
LC		Oscillator 2	20	90	20	90	10 μ H = 1 Ω 100 μ H = 5 Ω 1 mH = 75 Ω

Note

- 32 kHz quartz crystals with a series resistance >15 k Ω will reduce the guaranteed supply voltage range to 2.5 to 3.5 V.

Low voltage 8-bit microcontrollers with
UART and I²C-bus

P83CL781; P83CL782

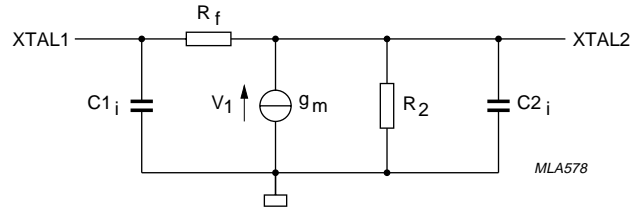

Fig.29 Oscillator equivalent circuit diagram.

Table 41 Oscillator equivalent circuit parameters

The equivalent circuit data of the internal oscillator compares with that of matched crystals.

SYMBOL	PARAMETER	OPTION	CONDITION	MIN.	TYP.	MAX.	UNIT
g_m	transconductance	Oscillator 1; 32 kHz	$T_{amb} = +25\text{ }^\circ\text{C};$ $V_{DD} = 4.5\text{ V}$	–	15	–	μS
		Oscillator 2		200	600	1000	μS
		Oscillator 3		400	1500	4000	μS
		Oscillator 4		1000	4000	10000	μS
C_{1i}	input capacitance	Oscillator 1; 32 kHz		–	3.0	–	pF
		Oscillator 2		–	8.0	–	pF
		Oscillator 3		–	8.0	–	pF
		Oscillator 4		–	8.0	–	pF
C_{2i}	output capacitance	Oscillator 1; 32 kHz		–	23	–	pF
		Oscillator 2		–	8.0	–	pF
		Oscillator 3		–	8.0	–	pF
		Oscillator 4		–	8.0	–	pF
R_2	output resistance	Oscillator 1; 32 kHz		–	3800	–	$\text{k}\Omega$
		Oscillator 2		–	65	–	$\text{k}\Omega$
		Oscillator 3		–	18	–	$\text{k}\Omega$
		Oscillator 4		–	5.0	–	$\text{k}\Omega$

Low voltage 8-bit microcontrollers with UART and I²C-bus

P83CL781; P83CL782

17 RESET

To initialize the P83CL78x a reset is performed by either of two methods:

- Applying an external signal to the RST pin
- Via Power-on reset circuitry.

The reset state of the port pins is mask-programmable and can be defined by the user. The standard reset value for Ports 0 to 3 is FFH. A reset leaves the internal registers as shown in Chapter 18.

17.1 External reset using the RST pin

The reset input for the P83CL78x is RST. A Schmitt trigger is used at the input for noise rejection. The output of the Schmitt trigger is sampled by the reset circuitry every machine cycle. A reset is accomplished by holding the RST pin HIGH for at least two machine cycles (24 oscillator periods) while the oscillator is running. The CPU responds by executing an internal reset. Port pins adopt their reset state immediately after the RST goes HIGH. During reset, ALE and PSEN are held HIGH.

The external reset is asynchronous to the internal clock. The RST pin is sampled during state 5, phase 2 of every machine cycle. After a HIGH is detected at the RST pin, an internal reset is repeated until RST goes LOW. The internal RAM is not affected by reset. When V_{DD} is turned on, the RAM contents are indeterminate.

17.2 Power-on reset

The device contains on-chip circuitry which switches the port pins to the customer defined logic level as soon as V_{DD} exceeds 1.3 V; if the mask option 'ON' has been chosen. As soon as the minimum supply voltage is reached, the oscillator will start up. However, to ensure that the oscillator is stable before the controller starts, the clock signals are gated away from the CPU for a further 1536 oscillator periods. A hysteresis of approximately 50 mV at a typical power-on switching level of 1.3 V will ensure correct operation. See Fig.32.

The on-chip Power-on reset circuitry can also be switched off via the mask option 'OFF'. This option reduces the Power-down current to typically 800 nA and can be chosen if external reset circuitry is used. For applications not requiring the internal reset, option 'OFF' should be chosen.

An automatic reset can be obtained by connecting the RST pin to V_{DD} via a 10 μF capacitor. At power-on, the voltage on the RST pin is equal to V_{DD} minus the capacitor voltage, and decreases from V_{DD} as the capacitor charges through the internal resistor (R_{RST}) to ground. The larger the capacitor, the more slowly V_{RST} decreases. V_{RST} must remain above the lower threshold of the Schmitt trigger long enough to effect a complete reset. The time required is the oscillator start-up time, plus 2 machine cycles. The Power-on reset circuitry is shown in Fig.31.

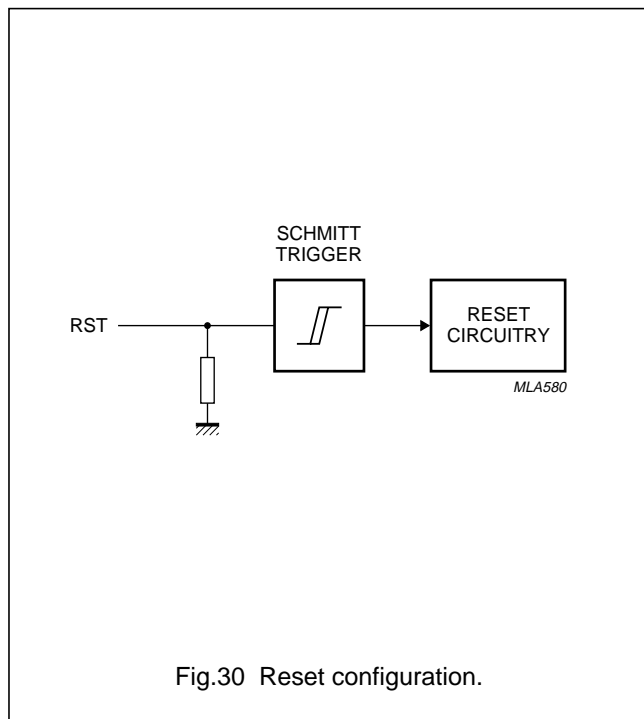

Fig.30 Reset configuration.

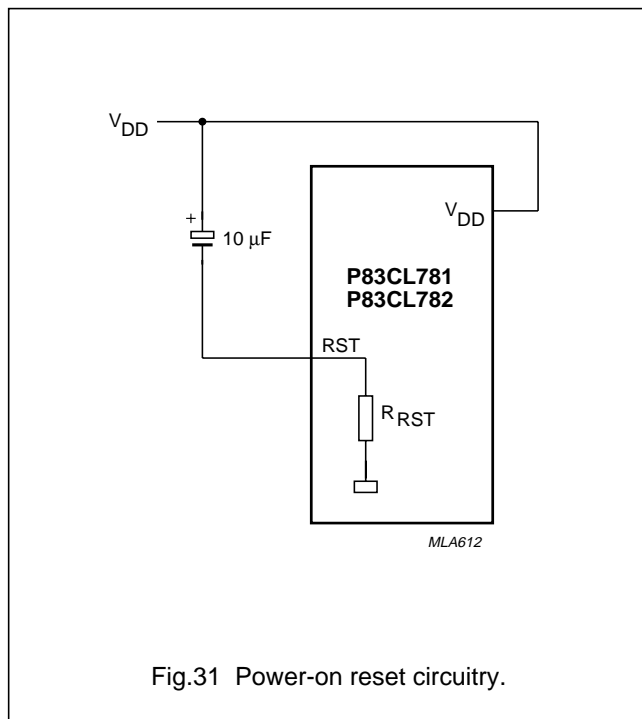

Fig.31 Power-on reset circuitry.

Low voltage 8-bit microcontrollers with UART and I²C-bus

P83CL781; P83CL782

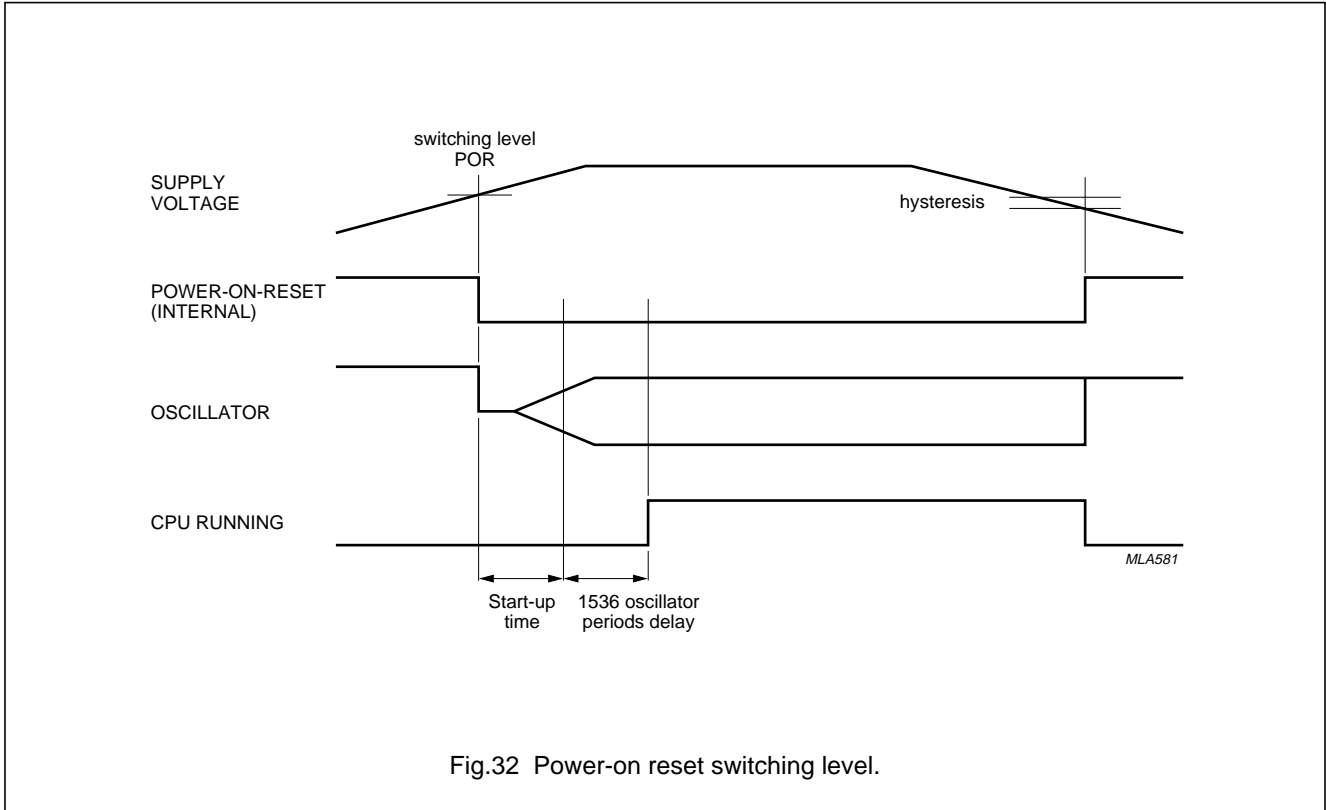

Fig.32 Power-on reset switching level.

Low voltage 8-bit microcontrollers with UART and I²C-bus

P83CL781; P83CL782

18 SPECIAL FUNCTION REGISTERS OVERVIEW

The P83CL78x has 34 SFRs available to the user.

ADDRESS (HEX)	NAME	RESET VALUE (B)	FUNCTION
F8	IP1 ⁽¹⁾	00000000	Interrupt Priority Register (INT2 to INT9)
F0	B ⁽¹⁾	00000000	B Register
E9	IX1	00000000	Interrupt Polarity Register
E8	IEN1 ⁽¹⁾	00000000	Interrupt Enable Register 1
E0	ACC ⁽¹⁾	00000000	Accumulator
DB	S1ADR	00000000	I ² C-bus Slave Address Register
DA	S1DAT	00000000	I ² C-bus Data Shift Register
D9	S1STA	1111 1000	I ² C-bus Serial Status Register
D8	S1CON ⁽¹⁾	00000000	I ² C-bus Serial Control Register
D0	PSW ⁽¹⁾	00000000	Program Status Word
CD	TH2	00000000	Timer 2 High byte
CC	TL2	00000000	Timer 2 Low byte
CB	RCAP2H	00000000	Timer 2 Reload/Capture Register High byte
CA	RCAP2L	00000000	Timer 2 Reload/Capture Register Low byte
C8	T2CON ⁽¹⁾	00000000	Timer/Counter 2 Control Register
C0	IRQ1 ⁽¹⁾	00000000	Interrupt Request Flag Register
B8	IP0 ⁽¹⁾	X000 0000	Interrupt Priority Register 0
B0	P3 ⁽¹⁾	XXXXXXXX ⁽²⁾	Digital I/O Port Register 3
A8	IEN0 ⁽¹⁾	00000000	Interrupt Enable Register
A0	P2 ⁽¹⁾	XXXXXXXX ⁽²⁾	Digital I/O Port Register 2
99	S0BUF	XXXXXXXX	Serial Data Buffer Register 0
98	S0CON ⁽¹⁾	00000000	Serial Port Control Register 0
90	P1 ⁽¹⁾	XXXXXXXX ⁽²⁾	Digital I/O Port Register 1
8D	TH1	00000000	Timer 1 High byte
8C	TH0	00000000	Timer 0 High byte
8B	TL1	00000000	Timer 1 Low byte
8A	TL0	00000000	Timer 0 Low byte
89	TMOD	00000000	Timer 0 and 1 Mode Control Register
88	TCON ⁽¹⁾	00000000	Timer 0 and 1 Control/External Interrupt Control Register
87	PCON	0XX00000	Power Control Register
83	DPH	00000000	Data Pointer High byte
82	DPL	00000000	Data Pointer Low byte
81	SP	00000111	Stack Pointer
80	P0 ⁽¹⁾	XXXXXXXX ⁽²⁾	Digital I/O Port Register 0

Notes

1. Bit addressable register.
2. Port reset state determined by the customer.

Low voltage 8-bit microcontrollers with UART and I²C-bus

P83CL781; P83CL782

19 INSTRUCTION SET

The P83CL78x uses a powerful instruction set which permits the expansion of on-chip CPU peripherals and optimizes byte efficiency and execution speed. Assigned opcodes add new high-power operation and permit new addressing modes. The instruction set consists of 49 single-byte, 46 two-byte and 16 three-byte instructions. When using a 12 MHz oscillator, 64 instructions execute in 1 μ s and 45 instructions execute in 2 μ s. Multiply and divide instructions execute in 4 μ s.

For the description of the **Data Addressing modes** and **Hexadecimal opcode cross-reference** see Table 46.

Table 42 Instruction set description: Arithmetic operations

MNEMONIC	DESCRIPTION	BYTES	CYCLES	OPCODE (HEX)
Arithmetic operations				
ADD A,Rr	Add register to A	1	1	2*
ADD A,direct	Add direct byte to A	2	1	25
ADD A,@Ri	Add indirect RAM to A	1	1	26, 27
ADD A,#data	Add immediate data to A	2	1	24
ADDC A,Rr	Add register to A with carry flag	1	1	3*
ADDC A,direct	Add direct byte to A with carry flag	2	1	35
ADDC A,@Ri	Add indirect RAM to A with carry flag	1	1	36, 37
ADDC A,#data	Add immediate data to A with carry flag	2	1	34
SUBB A,Rr	Subtract register from A with borrow	1	1	9*
SUBB A,direct	Subtract direct byte from A with borrow	2	1	95
SUBB A,@Ri	Subtract indirect RAM from A with borrow	1	1	96, 97
SUBB A,#data	Subtract immediate data from A with borrow	2	1	94
INC A	Increment A	1	1	04
INC Rr	Increment register	1	1	0*
INC direct	Increment direct byte	2	1	05
INC @Ri	Increment indirect RAM	1	1	06, 07
DEC A	Decrement A	1	1	14
DEC Rr	Decrement register	1	1	1*
DEC direct	Decrement direct byte	2	1	15
DEC @Ri	Decrement indirect RAM	1	1	16, 17
INC DPTR	Increment data pointer	1	2	A3
MUL AB	Multiply A and B	1	4	A4
DIV AB	Divide A by B	1	4	84
DA A	Decimal adjust A	1	1	D4

Low voltage 8-bit microcontrollers with UART and I²C-bus

P83CL781; P83CL782

Table 43 Instruction set description: Logic operations

MNEMONIC		DESCRIPTION	BYTES	CYCLES	OPCODE (HEX)
Logic operations					
ANL	A,Rr	AND register to A	1	1	5*
ANL	A,direct	AND direct byte to A	2	1	55
ANL	A,@Ri	AND indirect RAM to A	1	1	56, 57
ANL	A,#data	AND immediate data to A	2	1	54
ANL	direct,A	AND A to direct byte	2	1	52
ANL	direct,#data	AND immediate data to direct byte	3	2	53
ORL	A,Rr	OR register to A	1	1	4*
ORL	A,direct	OR direct byte to A	2	1	45
ORL	A,@Ri	OR indirect RAM to A	1	1	46, 47
ORL	A,#data	OR immediate data to A	2	1	44
ORL	direct,A	OR A to direct byte	2	1	42
ORL	direct,#data	OR immediate data to direct byte	3	2	43
XRL	A,Rr	Exclusive-OR register to A	1	1	6*
XRL	A,direct	Exclusive-OR direct byte to A	2	1	65
XRL	A,@Ri	Exclusive-OR indirect RAM to A	1	1	66, 67
XRL	A,#data	Exclusive-OR immediate data to A	2	1	64
XRL	direct,A	Exclusive-OR A to direct byte	2	1	62
XRL	direct,#data	Exclusive-OR immediate data to direct byte	3	2	63
CLR	A	Clear A	1	1	E4
CPL	A	Complement A	1	1	F4
RL	A	Rotate A left	1	1	23
RLC	A	Rotate A left through the carry flag	1	1	33
RR	A	Rotate A right	1	1	03
RRC	A	Rotate A right through the carry flag	1	1	13
SWAP	A	Swap nibbles within A	1	1	C4

Low voltage 8-bit microcontrollers with UART and I²C-bus

P83CL781; P83CL782

Table 44 Instruction set description: Data transfer

MNEMONIC		DESCRIPTION	BYTES	CYCLES	OPCODE (HEX)
Data transfer					
MOV	A,Rr	Move register to A	1	1	E*
MOV	A,direct (note 1)	Move direct byte to A	2	1	E5
MOV	A,@Ri	Move indirect RAM to A	1	1	E6, E7
MOV	A,#data	Move immediate data to A	2	1	74
MOV	Rr,A	Move A to register	1	1	F*
MOV	Rr,direct	Move direct byte to register	2	2	A*
MOV	Rr,#data	Move immediate data to register	2	1	7*
MOV	direct,A	Move A to direct byte	2	1	F5
MOV	direct,Rr	Move register to direct byte	2	2	8*
MOV	direct,direct	Move direct byte to direct	3	2	85
MOV	direct,@Ri	Move indirect RAM to direct byte	2	2	86, 87
MOV	direct,#data	Move immediate data to direct byte	3	2	75
MOV	@Ri,A	Move A to indirect RAM	1	1	F6, F7
MOV	@Ri,direct	Move direct byte to indirect RAM	2	2	A6, A7
MOV	@Ri,#data	Move immediate data to indirect RAM	2	1	76, 77
MOV	DPTR,#data 16	Load data pointer with a 16-bit constant	3	2	90
MOVC	A,@A+DPTR	Move code byte relative to DPTR to A	1	2	93
MOVC	A,@A+PC	Move code byte relative to PC to A	1	2	83
MOVX	A,@Ri	Move external RAM (8-bit address) to A	1	2	E2, E3
MOVX	A,@DPTR	Move external RAM (16-bit address) to A	1	2	E0
MOVX	@Ri,A	Move A to external RAM (8-bit address)	1	2	F2, F3
MOVX	@DPTR,A	Move A to external RAM (16-bit address)	1	2	F0
PUSH	direct	Push direct byte onto stack	2	2	C0
POP	direct	Pop direct byte from stack	2	2	D0
XCH	A,Rr	Exchange register with A	1	1	C*
XCH	A,direct	Exchange direct byte with A	2	1	C5
XCH	A,@Ri	Exchange indirect RAM with A	1	1	C6, C7
XCHD	A,@Ri	Exchange LOW-order digit indirect RAM with A	1	1	D6, D7

Note

1. MOV A,ACC is not permitted.

Low voltage 8-bit microcontrollers with UART and I²C-bus

P83CL781; P83CL782

Table 45 Instruction set description: Boolean variable manipulation, Program and machine control

MNEMONIC	DESCRIPTION	BYTES	CYCLES	OPCODE (HEX)
Boolean variable manipulation				
CLR C	Clear carry flag	1	1	C3
CLR bit	Clear direct bit	2	1	C2
SETB C	Set carry flag	1	1	D3
SETB bit	Set direct bit	2	1	D2
CPL C	Complement carry flag	1	1	B3
CPL bit	Complement direct bit	2	1	B2
ANL C,bit	AND direct bit to carry flag	2	2	82
ANL C,/bit	AND complement of direct bit to carry flag	2	2	B0
ORL C,bit	OR direct bit to carry flag	2	2	72
ORL C,/bit	OR complement of direct bit to carry flag	2	2	A0
MOV C,bit	Move direct bit to carry flag	2	1	A2
MOV bit,C	Move carry flag to direct bit	2	2	92
Program and machine control				
ACALL addr11	Absolute subroutine call	2	2	•1
LCALL addr16	Long subroutine call	3	2	12
RET	Return from subroutine	1	2	22
RETI	Return from interrupt	1	2	32
AJMP addr11	Absolute jump	2	2	♦1
LJMP addr16	Long jump	3	2	02
SJMP rel	Short jump (relative address)	2	2	80
JMP @A+DPTR	Jump indirect relative to the DPTR	1	2	73
JZ rel	Jump if A is zero	2	2	60
JNZ rel	Jump if A is not zero	2	2	70
JC rel	Jump if carry flag is set	2	2	40
JNC rel	Jump if carry flag is not set	2	2	50
JB bit,rel	Jump if direct bit is set	3	2	20
JNB bit,rel	Jump if direct bit is not set	3	2	30
JBC bit,rel	Jump if direct bit is set and clear bit	3	2	10
CJNE A,direct,rel	Compare direct to A and jump if not equal	3	2	B5
CJNE A,#data,rel	Compare immediate to A and jump if not equal	3	2	B4
CJNE Rr,#data,rel	Compare immediate to register and jump if not equal	3	2	B*
CJNE @Ri,#data,rel	Compare immediate to indirect and jump if not equal	3	2	B6, B7
DJNZ Rr,rel	Decrement register and jump if not zero	2	2	D*
DJNZ direct,rel	Decrement direct and jump if not zero	3	2	D5
NOP	No operation	1	1	00

Low voltage 8-bit microcontrollers with UART and I²C-bus

P83CL781; P83CL782

Table 46 Description of the mnemonics in the Instruction set

MNEMONIC	DESCRIPTION
Data addressing modes	
Rr	Working register R0-R7.
direct	128 internal RAM locations and any special function register (SFR).
@Ri	Indirect internal RAM location addressed by register R0 or R1 of the actual register bank.
#data	8-bit constant included in instruction.
#data 16	16-bit constant included as bytes 2 and 3 of instruction.
bit	Direct addressed bit in internal RAM or SFR.
addr16	16-bit destination address. Used by LCALL and LJMP. The branch will be anywhere within the 64 kbytes Program Memory address space.
addr11	111-bit destination address. Used by ACALL and AJMP. The branch will be within the same 2 kbytes page of Program Memory as the first byte of the following instruction.
rel	Signed (two's complement) 8-bit offset byte. Used by SJMP and all conditional jumps. Range is -128 to +127 bytes relative to first byte of the following instruction.
Hexadecimal opcode cross-reference	
*	8, 9, A, B, C, D, E, F.
•	1, 3, 5, 7, 9, B, D, F.
◆	0, 2, 4, 6, 8, A, C, E.

Low voltage 8-bit microcontrollers with
UART and I²C-bus

P83CL781; P83CL782

Table 47 Instruction map

↓	← First hexadecimal character of opcode							← Second hexadecimal character of opcode →							
	0	1	2	3	4	5	6	7	8	9	A	B	C	D	E
0	NOP	AJMP addr11	LJMP addr16	RR A	INC A	INC direct	INC @Ri 0 1		INC Rr 0 1 2 3 4 5 6 7						
1	JBC bit,rel	ACALL addr11	LCALL addr16	RRC A	DEC A	DEC direct	DEC @Ri 0 1		DEC Rr 0 1 2 3 4 5 6 7						
2	JB bit,rel	AJMP addr11	RET	RL A	ADD A,#data	ADD A,direct	ADD A,@Ri 0 1		ADD A,Rr 0 1 2 3 4 5 6 7						
3	JNB bit,rel	ACALL addr11	RETI	RLC A	ADDC A,#data	ADDC A,direct	ADDC A,@Ri 0 1		ADDC A,Rr 0 1 2 3 4 5 6 7						
4	JC rel	AJMP addr11	ORL direct,A	ORL direct,#data	ORL A,#data	ORL A,direct	ORL A,@Ri 0 1		ORL A,Rr 0 1 2 3 4 5 6 7						
5	JNC rel	ACALL addr11	ANL direct,A	ANL direct,#data	ANL A,#data	ANL A,direct	ANL A,@Ri 0 1		ANL A,Rr 0 1 2 3 4 5 6 7						
6	JZ rel	AJMP addr11	XRL direct,A	XRL direct,#data	XRL A,#data	XRL A,direct	XRL A,@Ri 0 1		XRL A,Rr 0 1 2 3 4 5 6 7						
7	JNZ rel	ACALL addr11	ORL C,bit	JMP @A+DPTR	MOV A,#data	MOV direct,#data	MOV @Ri,#data 0 1		MOV Rr,#data 0 1 2 3 4 5 6 7						
8	SJMP rel	AJMP addr11	ANL C,bit	MOVC A,@A+PC	DIV AB	MOV direct,direct	MOV direct,@Ri 0 1		MOV direct,Rr 0 1 2 3 4 5 6 7						
9	MOV DTPR,#data16	ACALL addr11	MOV bit,C	MOVC A,@A+DPTR	SUBB A,#data	SUBB A,direct	SUBB A,@Ri 0 1		SUB A,Rr 0 1 2 3 4 5 6 7						
A	ORL C,/bit	AJMP addr11	MOV bit,C	INC DPTR	MUL AB		MOV @Ri,direct 0 1		MOV Rr,direct 0 1 2 3 4 5 6 7						
B	ANL C,/bit	ACALL addr11	CPL bit	CPL C	CJNE A,#data,rel	CJNE A,direct,rel	CJNE @Ri,#data,rel 0 1		CJNE Rr,#data,rel 0 1 2 3 4 5 6 7						
C	PUSH direct	AJMP addr11	CLR bit	CLR C	SWAP A	XCH A,direct	XCH A,@Ri 0 1		XCH A,Rr 0 1 2 3 4 5 6 7						
D	POP direct	ACALL addr11	SETB bit	SETB C	DA A	DJNZ direct,rel	XCHD A,@Ri 0 1		DJNZ Rr,rel 0 1 2 3 4 5 6 7						
E	MOVX A,@DTPR	AJMP addr11	MOVX A,@Ri 0 1		CLR A	MOV A,direct ⁽¹⁾	MOV A,@Ri 0 1		MOV A,Rr 0 1 2 3 4 5 6 7						
F	MOVX @DTPR,A	ACALL addr11	MOVX @Ri,A 0 1		CPL A	MOV direct,A	MOV @Ri,A 0 1		MOV Rr,A 0 1 2 3 4 5 6 7						

Note

- MOV A, ACC is not a valid instruction.

Low voltage 8-bit microcontrollers with UART and I²C-bus

P83CL781; P83CL782

20 LIMITING VALUES

In accordance with the Absolute Maximum Rating System (IEC 134)

SYMBOL	PARAMETER	MIN.	MAX.	UNIT
V _{DD}	supply voltage	-0.5	+6.5	V
V _I	input voltage on any pin with respect to ground (V _{SS})	-0.5	V _{DD} + 0.5	V
I _I	DC current on any input	-5.0	+5.0	mA
I _O	DC current on any output	-5.0	+5.0	mA
P _{tot}	total power dissipation	-	300	mW
T _{stg}	storage temperature	-65	+150	°C
T _{amb}	operating ambient temperature - P83CL781	-40	+85	°C
	operating ambient temperature - P83CL782	-25	+55	°C
T _j	operating junction temperature	-	+125	°C

21 DC CHARACTERISTICS

The DC characteristics apply to both the P83CL781 and the P83CL782 unless otherwise stated. V_{DD} = 1.8 to 6 V; V_{SS} = 0 V; T_{amb} = -40 to +85 °C for the P83CL781 and -25 to +55 °C for the P83CL782; all voltages with respect to V_{SS} unless otherwise specified. See notes 1, 2 and 3.

SYMBOL	PARAMETER	CONDITIONS	MIN.	TYP.	MAX.	UNIT
Supply						
V _{DD}	supply voltage		1.8	-	6.0	V
V _{DD}	RAM retention voltage in Power-down mode		1.0	-	6.0	V
I _{DD}	supply current operating; P83CL781	V _{DD} = 5 V; f _{CLK} = 12 MHz; note 4	-	17	25	mA
		V _{DD} = 3 V; f _{CLK} = 3.58 MHz; note 4	-	2.4	5	mA
	supply current operating; P83CL782	V _{DD} = 3.1 V; f _{CLK} = 12 MHz; note 4	-	8.4	12	mA
		V _{DD} = 3 V; f _{CLK} = 3.58 MHz; note 4	-	2.4	5	μA
I _{DD(idle)}	supply current Idle mode; P83CL781	V _{DD} = 5 V; f _{CLK} = 12 MHz; note 5	-	5.1	12	mA
		V _{DD} = 3 V; f _{CLK} = 3.58 MHz; note 5	-	0.75	3	mA
	supply current Idle mode; P83CL782	V _{DD} = 5 V; f _{CLK} = 12 MHz; note 5	-	2.7	5	mA
		V _{DD} = 3 V; f _{CLK} = 3.58 MHz; note 5	-	0.75	3	mA
I _{DD(pd)}	supply current Power-down mode	V _{DD} = 1.8 V; T _{amb} = 25 °C; note 6	-	-	10	μA

Low voltage 8-bit microcontrollers with UART and I²C-bus

P83CL781; P83CL782

SYMBOL	PARAMETER	CONDITIONS	MIN.	TYP.	MAX.	UNIT
Inputs						
V _{IL}	LOW level input voltage	note 7	V _{SS}	–	0.3V _{DD}	V
V _{IH}	HIGH level input voltage	note 7	0.7V _{DD}	–	V _{DD}	V
I _{IL}	LOW level input current	V _{DD} = 5 V; V _{IN} = 0.4 V; note 7	–	–	–100	μA
		V _{DD} = 2.5 V; V _{IN} = 0.4 V; note 7	–	–	–50	μA
I _{IL(T)}	LOW level input current (HIGH-to-LOW transition)	V _{DD} = 5 V; V _{IN} = 0.5V _{DD} ; note 7	–	–	–1.0	mA
		V _{DD} = 2.5 V; V _{IN} = 0.5V _{DD} ; note 7	–	–	–500	μA
I _{LI}	input leakage current	V _{SS} < V _I < V _{DD} ; note 7	–	–	±10	μA
Outputs						
I _{OL}	LOW level output current; except SDA and SCL	V _{DD} = 5 V; V _{OL} = 0.4 V	1.6	–	–	mA
		V _{DD} = 2.5 V; V _{OL} = 0.4 V	0.7	–	–	mA
I _{OL1}	LOW level output current; SDA and SCL	V _{DD} = 5 V; V _{OL} = 0.4 V	3.0	–	–	mA
I _{OH}	HIGH level output current (push-pull options only)	V _{DD} = 5 V; V _{OH} = V _{DD} – 0.4 V	–1.6	–	–	mA
		V _{DD} = 2.5 V; V _{OH} = V _{DD} – 0.4 V	–0.7	–	–	mA
R _{RST}	RST pull-down resistor		10	–	200	kΩ

Notes

- Capacitive loading on Ports 0 and 2 may cause spurious noise pulses to be superimposed on the LOW level output voltage of ALE, Port 1 and Port 3 pins when these make a HIGH-to-LOW transition during bus operations. The noise is due to external bus capacitance discharging into the Port 0 and Port 2 pins when these pins make HIGH-to-LOW transitions during bus operations. In the most adverse conditions (capacitive loading >100 pF), the noise pulse on the ALE line may exceed 0.8 V. In such events it may be required to qualify ALE with a Schmitt trigger, or use an address latch with a Schmitt trigger strobe input.
- Capacitive loading on Ports 0 and 2 may cause the HIGH level output voltage on ALE and $\overline{\text{PSEN}}$ to momentarily fall below the 0.9% of V_{DD} specification when the address bits are stabilizing.
- Circuits with Power-on reset option 'OFF' are tested at V_{DDmin} = 1.8 V; with the 'ON' option (typically 1.3 V) they are tested at V_{DDmin} = 2.3 V.
- The operating supply current is measured with all output pins disconnected; XTAL1 driven with t_r = t_f = 10 ns; V_{IL} = V_{SS}; V_{IH} = V_{DD}; XTAL2 not connected; $\overline{\text{EA}}$ = RST = Port 0 = V_{DD}.
- The Idle mode supply current is measured with all output pins disconnected; XTAL1 driven with t_r = t_f = 10 ns; V_{IL} = V_{SS}; V_{IH} = V_{DD}; XTAL2 not connected; $\overline{\text{EA}}$ = Port 0 = V_{DD}.
- The Power-down current is measured with all output pins disconnected; XTAL1 not connected; $\overline{\text{EA}}$ = Port 0 = V_{DD}; RST = V_{SS}.
- The input threshold voltage of P1.6/SCL and P1.7/SDA meet the I²C-bus specification. Therefore, an input voltage below 0.3V_{DD} will be recognized as a logic 0 and an input voltage above 0.7V_{DD} will be recognized as a logic 1.

Low voltage 8-bit microcontrollers with
UART and I²C-bus

P83CL781; P83CL782

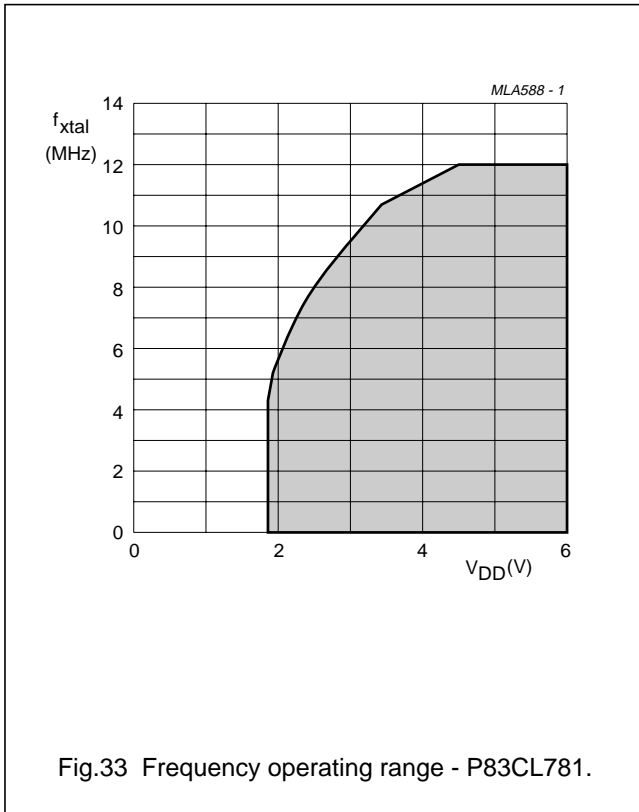

Fig.33 Frequency operating range - P83CL781.

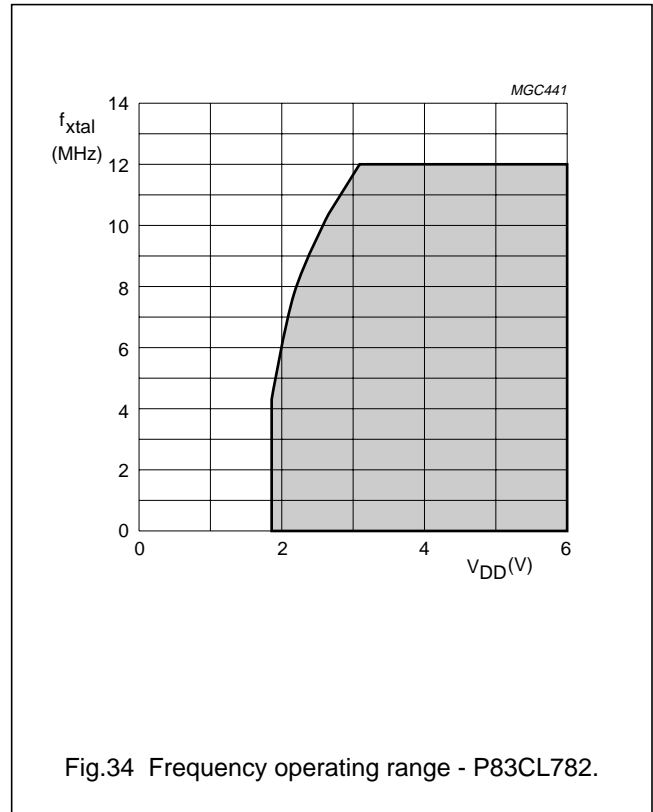
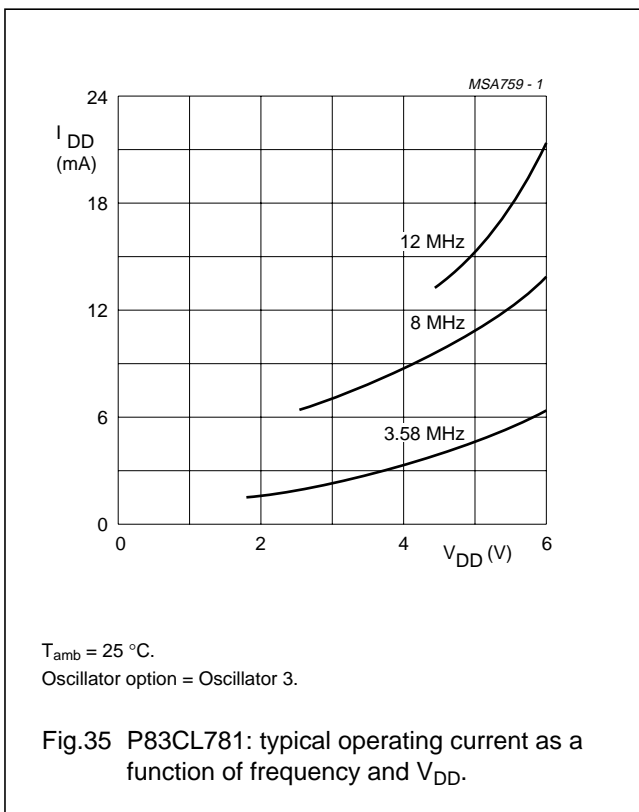
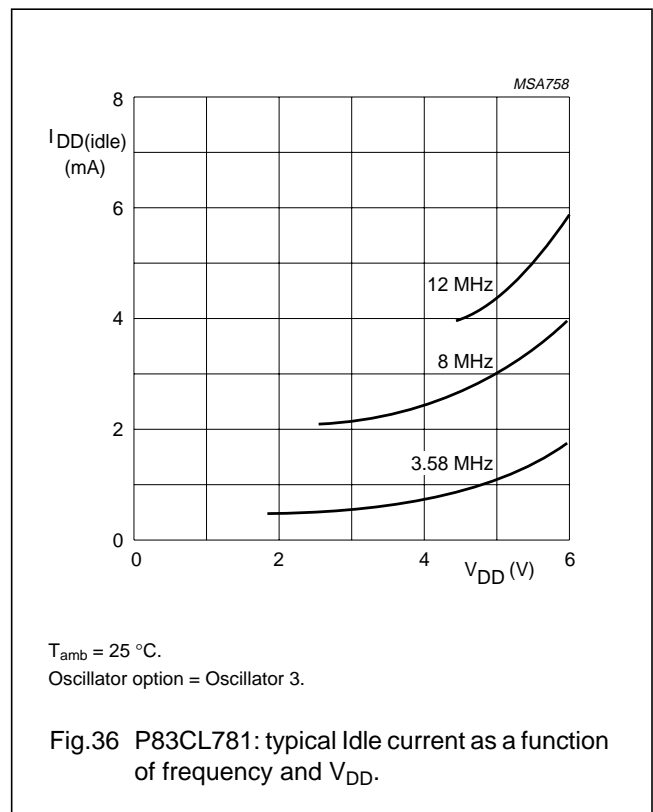

Fig.34 Frequency operating range - P83CL782.



$T_{amb} = 25\text{ }^{\circ}\text{C}$.
Oscillator option = Oscillator 3.

Fig.35 P83CL781: typical operating current as a function of frequency and V_{DD} .



$T_{amb} = 25\text{ }^{\circ}\text{C}$.
Oscillator option = Oscillator 3.

Fig.36 P83CL781: typical Idle current as a function of frequency and V_{DD} .

Low voltage 8-bit microcontrollers with
UART and I²C-bus

P83CL781; P83CL782

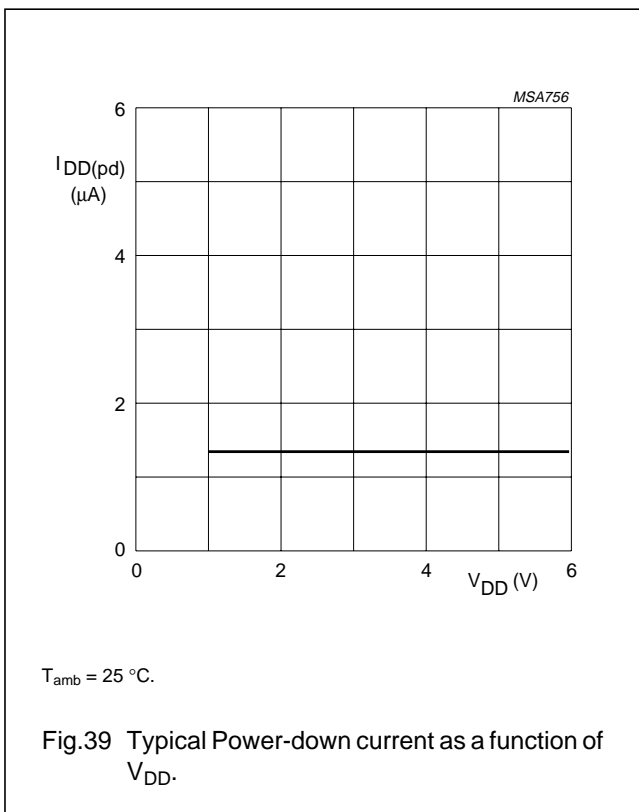
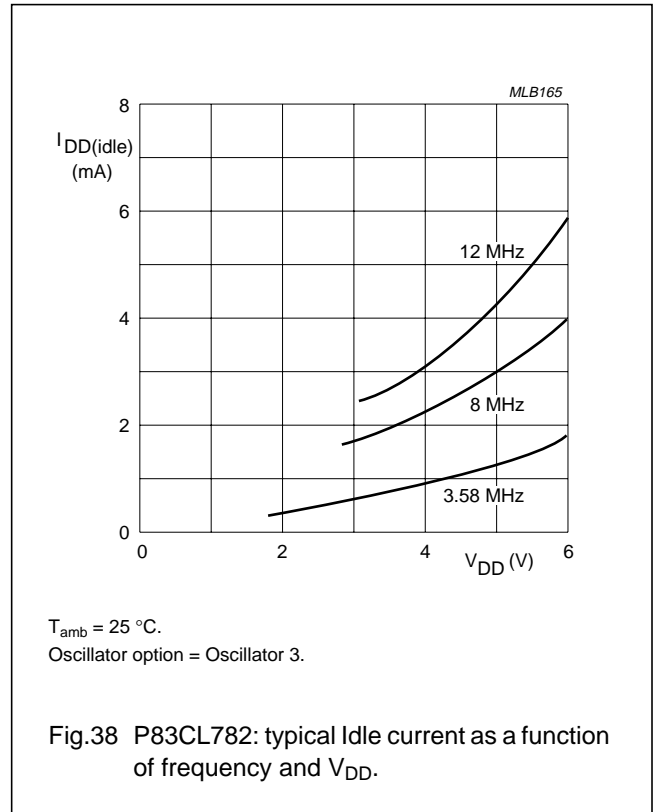
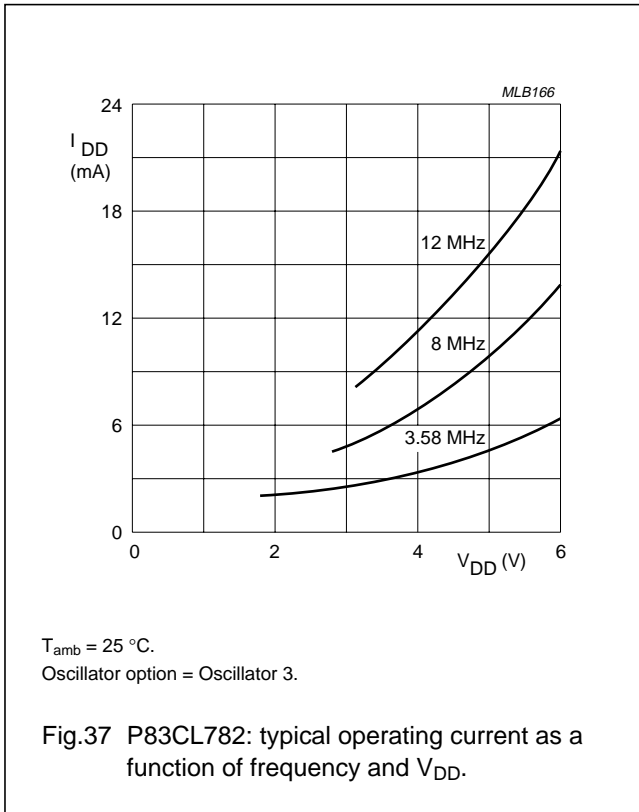

Low voltage 8-bit microcontrollers with UART and I²C-bus

P83CL781; P83CL782

22 AC CHARACTERISTICS

The following AC characteristics apply to both the P83CL781 and P83CL782 unless otherwise stated.

22.1 Program memory

V_{DD} = 5 V; V_{SS} = 0 V; T_{amb} = -40 to +85 °C for the P83CL781 and -25 to +55 °C for the P83CL782; C_L = 50 pF for Port 0, ALE and PSEN; C_L = 80 pF for all other outputs unless specified. See Fig.40.

SYMBOL	PARAMETER	f _{osc} = 12 MHz		f _{osc} = VARIABLE		UNIT
		MIN.	MAX.	MIN.	MAX.	
t _{LL}	ALE pulse duration	127	-	2t _{CK} - 40	-	ns
t _{AL}	Address set-up time to ALE	43	-	t _{CK} - 40	-	ns
t _{LA}	Address hold time after ALE	48	-	t _{CK} - 35	-	ns
t _{LIV}	Time from ALE to valid instruction input	-	233	-	4t _{CK} - 100	ns
t _{LC}	Time from ALE to control pulse PSEN	58	-	t _{CK} - 25	-	ns
t _{CC}	Control pulse duration PSEN	215	-	3t _{CK} - 35	-	ns
t _{CIV}	Time from PSEN to valid instruction input	-	125	-	3t _{CK} - 125	ns
t _{CI}	Input instruction hold time after PSEN	0	-	0	-	ns
t _{CIF}	Input instruction float delay after PSEN	-	63	-	t _{CK} - 20	ns
t _{AC}	Address valid after PSEN	75	-	t _{CK} - 8	-	ns
t _{AIV}	Address to valid instruction input	-	302	-	5t _{CK} - 115	ns
t _{AFC}	Address float delay after PSEN	12	-	0	-	ns

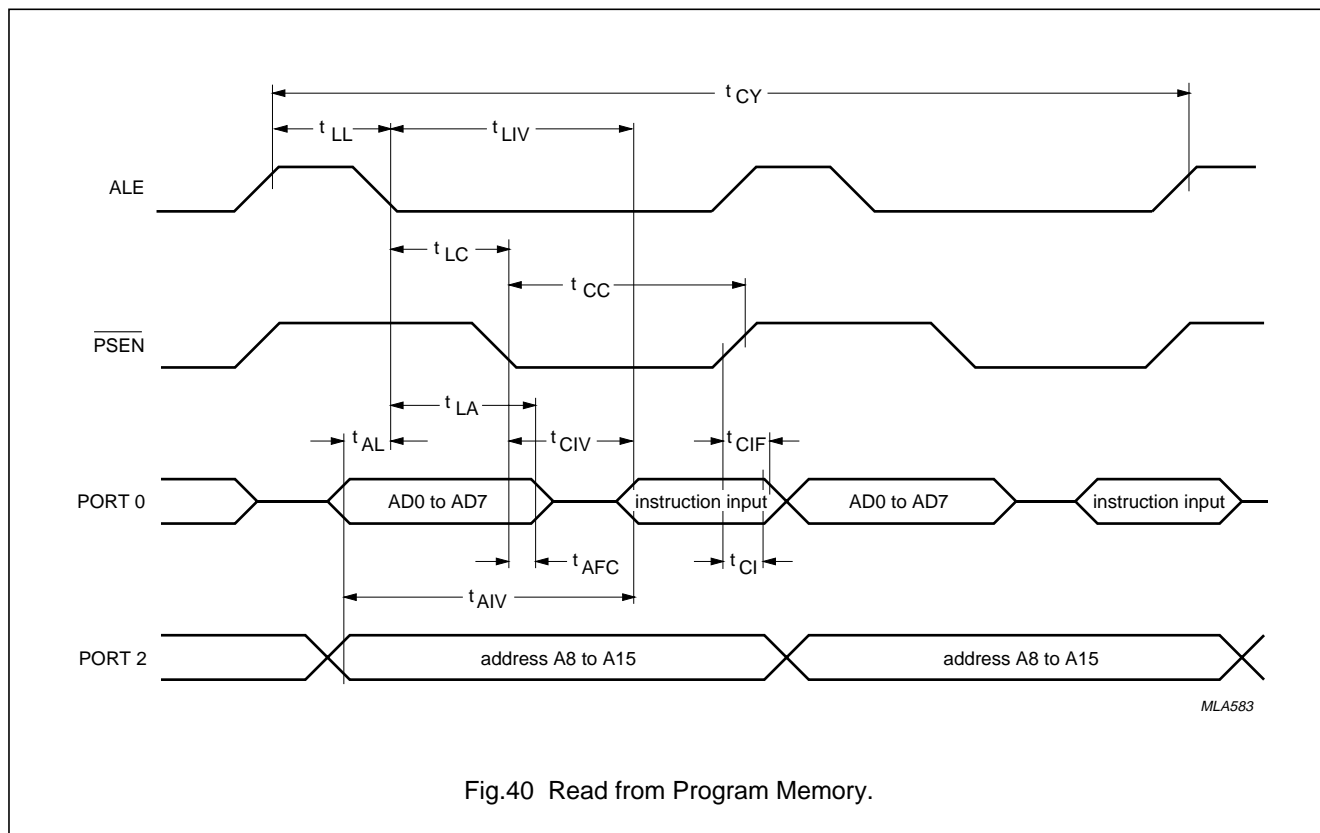

Fig.40 Read from Program Memory.

Low voltage 8-bit microcontrollers with UART and I²C-bus

P83CL781; P83CL782

22.2 External Data Memory

$V_{DD} = 5\text{ V}$; $V_{SS} = 0\text{ V}$; $T_{amb} = -40\text{ to }+85\text{ }^{\circ}\text{C}$ for P83CL781 and $-25\text{ to }+55\text{ }^{\circ}\text{C}$ for the P83CL782; $C_L = 50\text{ pF}$ for Port 0, ALE and PSEN; $C_L = 40\text{ pF}$ for all other outputs unless specified. See note 1 and Figs 41 and 42.

SYMBOL	PARAMETER	$f_{osc} = 12\text{ MHz}$		$f_{osc} = \text{VARIABLE}$		UNIT
		MIN.	MAX.	MIN.	MAX.	
t_{RR}	\overline{RD} pulse duration	400	–	$6t_{CK} - 100$	–	ns
t_{WW}	\overline{WR} pulse duration	400	–	$6t_{CK} - 100$	–	ns
t_{LA}	Address hold time after ALE	48	–	$t_{CK} - 35$	–	ns
t_{RD}	\overline{RD} to valid data input	–	150	–	$5t_{CK} - 165$	ns
t_{DFR}	Data float delay after \overline{RD}	–	97	–	$2t_{CK} - 70$	ns
t_{LD}	Time from ALE to valid data input	–	517	–	$8t_{CK} - 150$	ns
t_{AD}	Address to valid data input	–	585	–	$9t_{CK} - 165$	ns
t_{LW}	Time from ALE to \overline{RD} or \overline{WR}	200	300	$3t_{CK} - 50$	$3t_{CK} + 50$	ns
t_{AW}	Time from address to \overline{RD} or \overline{WR}	203	–	4	–	ns
t_{WHLH}	Time from \overline{RD} or \overline{WR} HIGH to ALE HIGH	43	123	$t_{CK} - 40$	$t_{CK} + 40$	ns
t_{DWX}	Data valid to \overline{WR} transition	23	–	$t_{CK} - 60$	–	ns
t_{DW}	Data set-up time before \overline{WR}	433	–	$7t_{CK} - 150$	–	ns
t_{WD}	Data hold time after \overline{WR}	33	–	$t_{CK} - 50$	–	ns
t_{AFR}	Address float delay after \overline{RD}	–	12	–	12	ns

Note

1. Interfacing the P83CL781 or the P83CL782 to devices with float times up to 75 ns is permitted. This limited bus contention will not cause damage to Port 0 drivers.

Low voltage 8-bit microcontrollers with
UART and I²C-bus

P83CL781; P83CL782

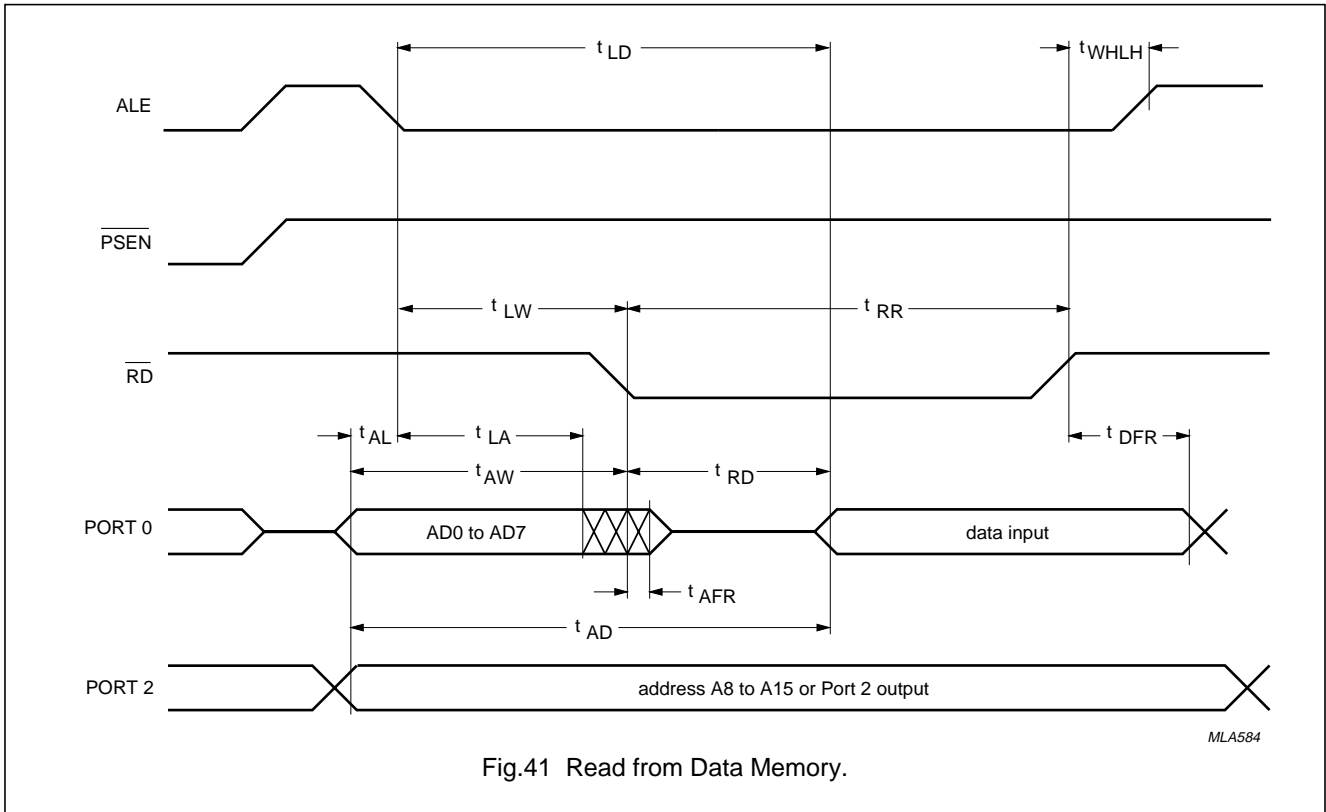

Fig.41 Read from Data Memory.

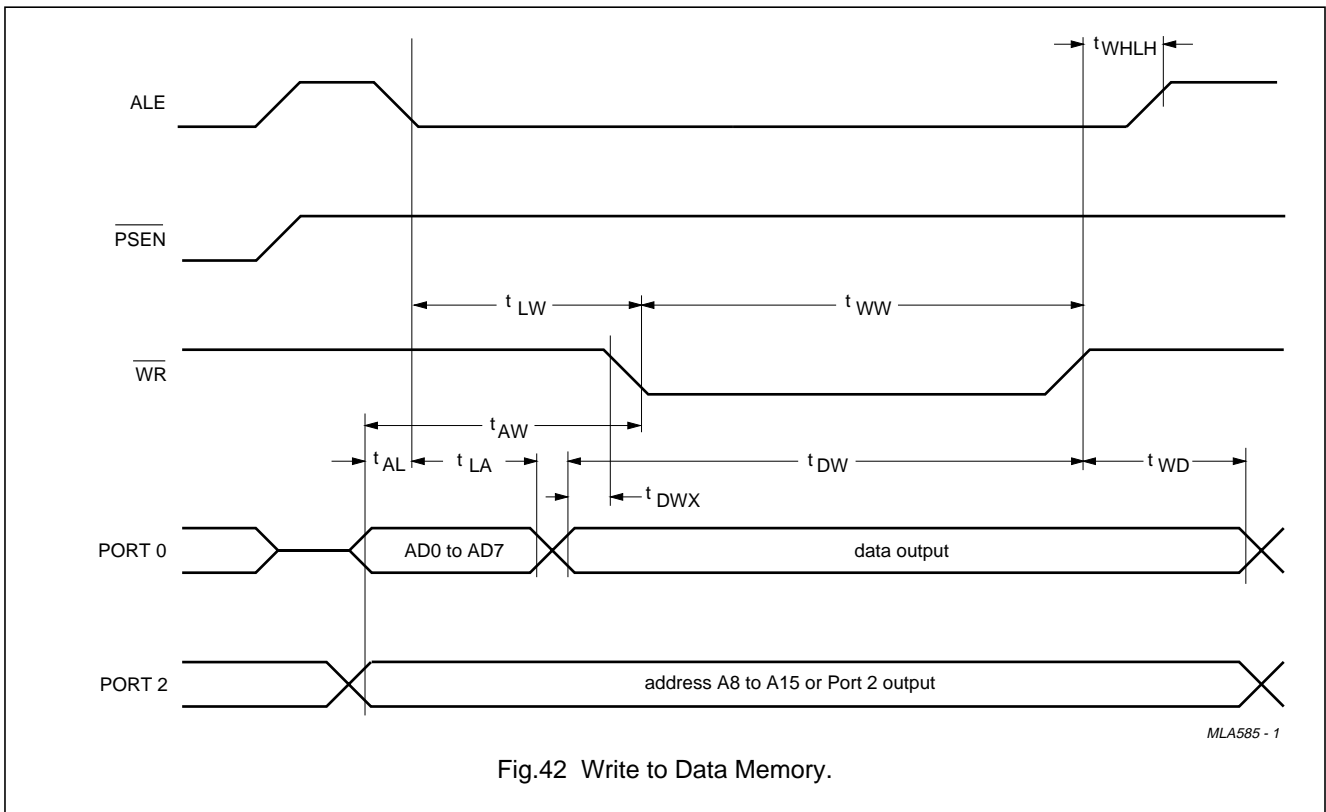

Fig.42 Write to Data Memory.

Low voltage 8-bit microcontrollers with UART and I²C-bus

P83CL781; P83CL782

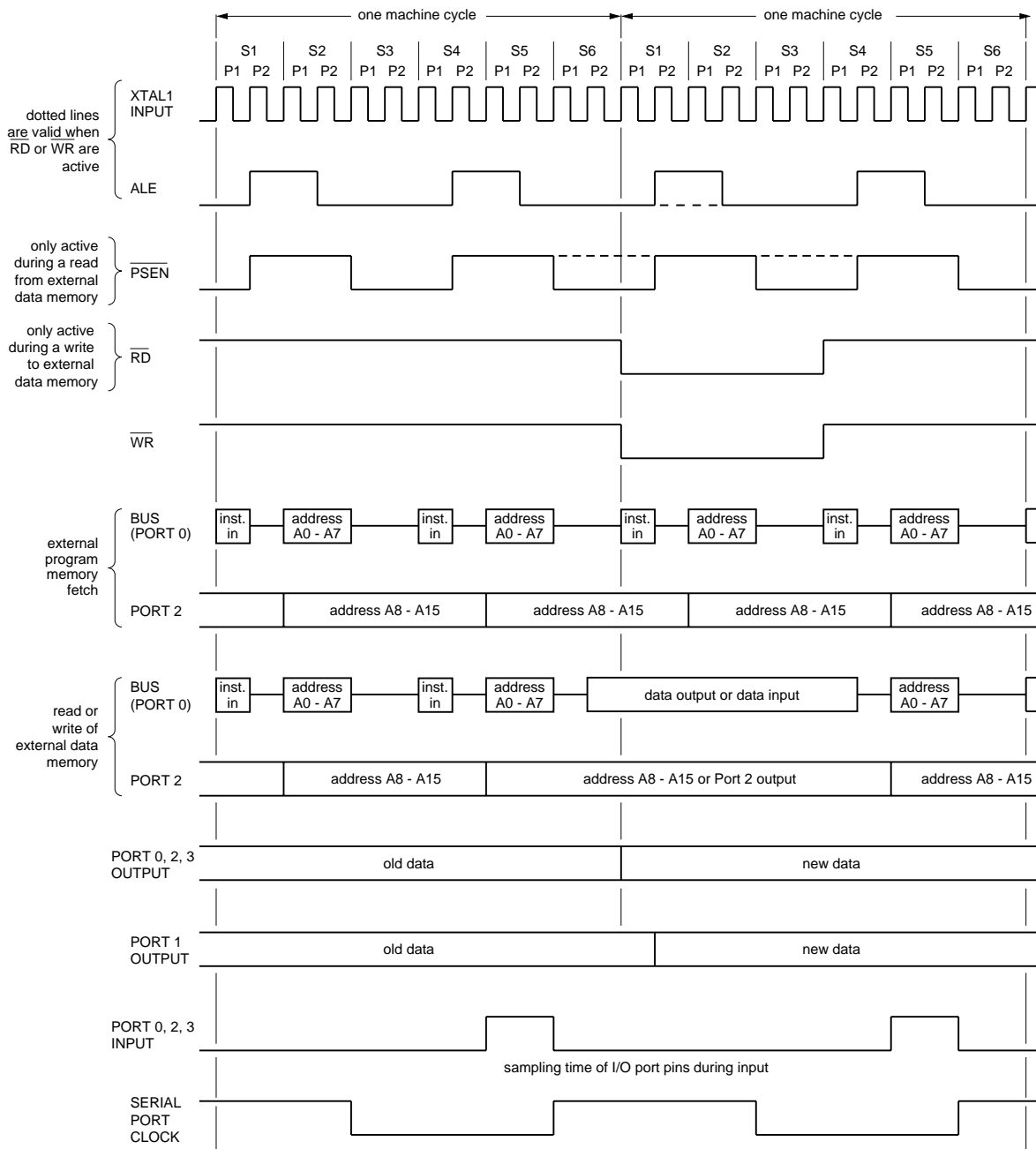

Fig.43 Instruction cycle timing.

Low voltage 8-bit microcontrollers with
UART and I²C-bus

P83CL781; P83CL782

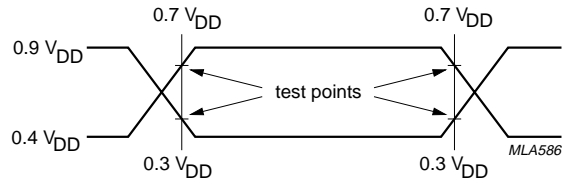

Fig.44 AC testing input waveform.

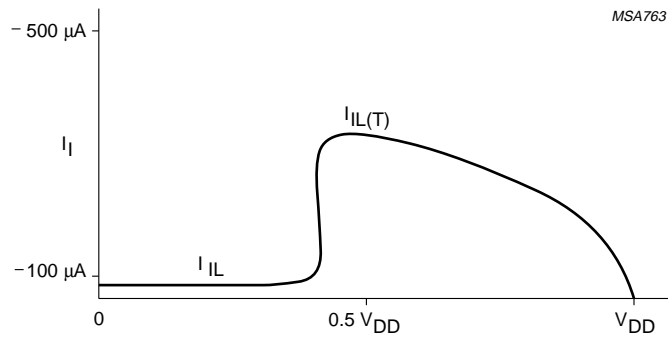

Fig.45 Input current.

Low voltage 8-bit microcontrollers with UART and I²C-bus

P83CL781; P83CL782

23 PACKAGE OUTLINES

DIP40: plastic dual in-line package; 40 leads (600 mil)

SOT129-1

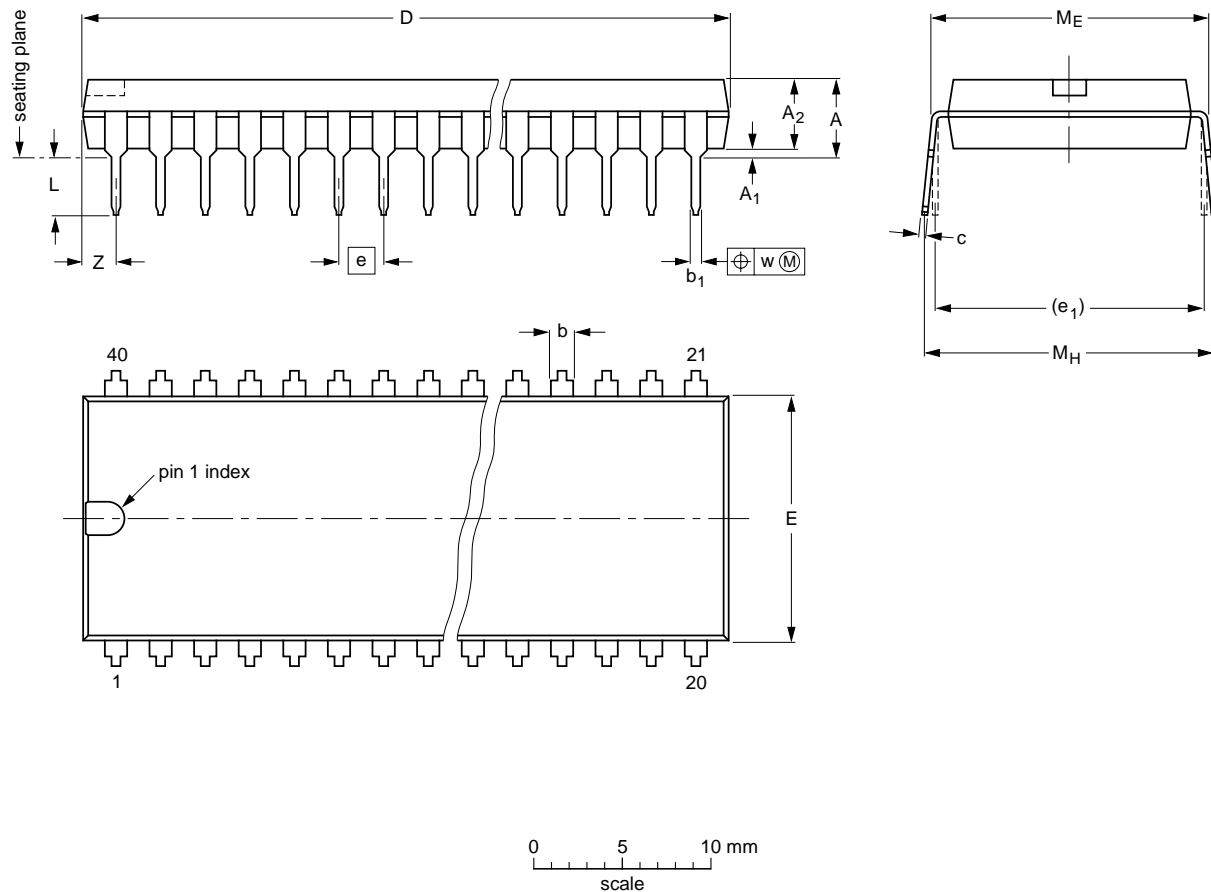

DIMENSIONS (inch dimensions are derived from the original mm dimensions)

UNIT	A max.	A ₁ min.	A ₂ max.	b	b ₁	c	D ⁽¹⁾	E ⁽¹⁾	e	e ₁	L	M _E	M _H	w	Z ⁽¹⁾ max.
mm	4.7	0.51	4.0	1.70 1.14	0.53 0.38	0.36 0.23	52.50 51.50	14.1 13.7	2.54	15.24	3.60 3.05	15.80 15.24	17.42 15.90	0.254	2.25
inches	0.19	0.020	0.16	0.067 0.045	0.021 0.015	0.014 0.009	2.067 2.028	0.56 0.54	0.10	0.60	0.14 0.12	0.62 0.60	0.69 0.63	0.01	0.089

Note

1. Plastic or metal protrusions of 0.25 mm maximum per side are not included.

OUTLINE VERSION	REFERENCES				EUROPEAN PROJECTION	ISSUE DATE
	IEC	JEDEC	EIAJ			
SOT129-1	051G08	MO-015AJ				92-11-17 95-01-14

Low voltage 8-bit microcontrollers with
UART and I²C-bus

P83CL781; P83CL782

QFP44: plastic quad flat package; 44 leads (lead length 2.35 mm); body 14 x 14 x 2.2 mm

SOT205-1

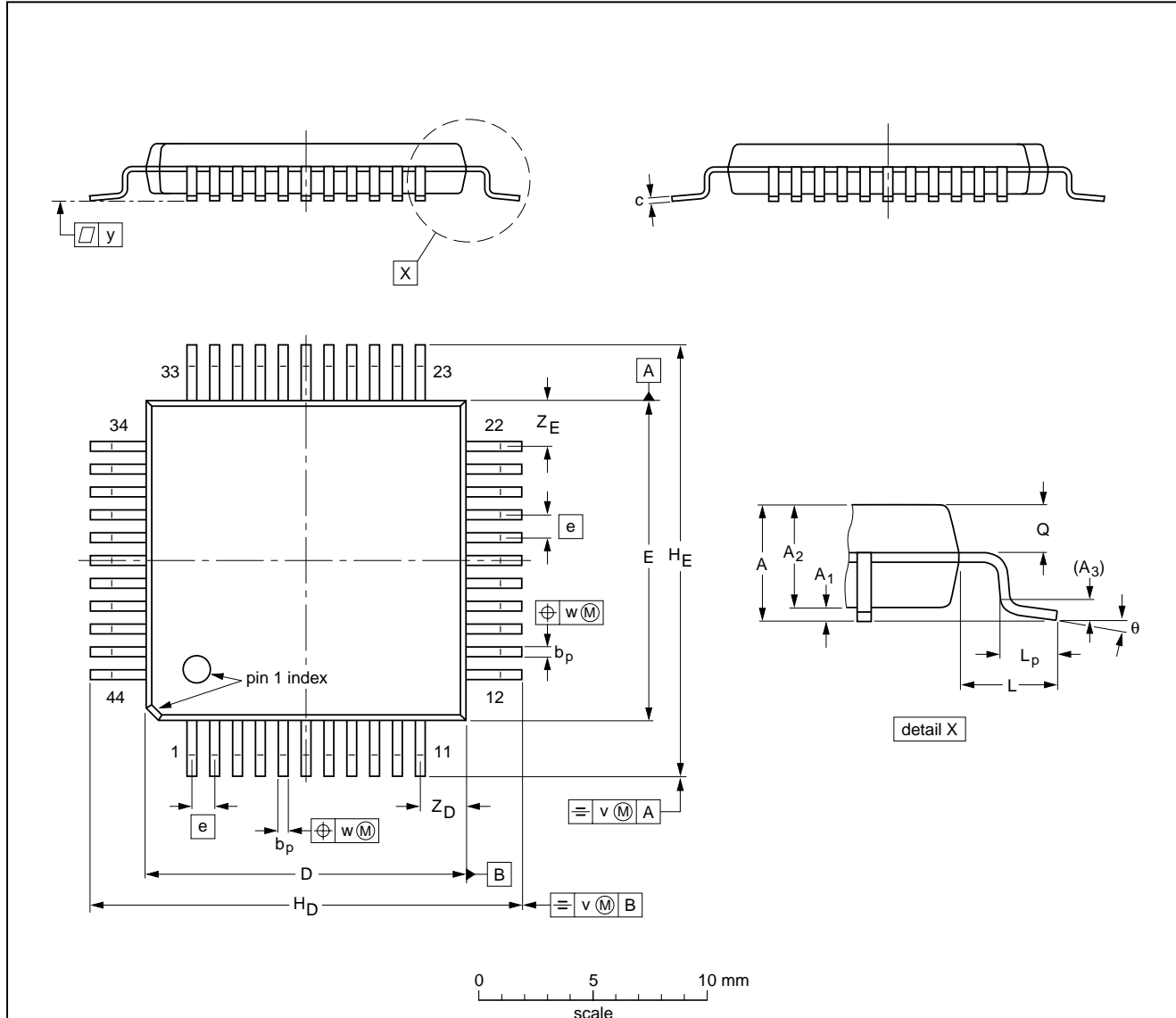

DIMENSIONS (mm are the original dimensions)

UNIT	A max.	A ₁	A ₂	A ₃	b _p	c	D ⁽¹⁾	E ⁽¹⁾	e	H _D	H _E	L	L _p	Q	v	w	y	Z _D ⁽¹⁾	Z _E ⁽¹⁾	θ
mm	2.60	0.25 0.05	2.3 2.1	0.25	0.50 0.35	0.25 0.14	14.1 13.9	14.1 13.9	1	19.2 18.2	19.2 18.2	2.35	2.0 1.2	1.2 0.9	0.3	0.15	0.1	2.4 1.8	2.4 1.8	7° 0°

Note

1. Plastic or metal protrusions of 0.25 mm maximum per side are not included.

OUTLINE VERSION	REFERENCES				EUROPEAN PROJECTION	ISSUE DATE
	IEC	JEDEC	EIAJ			
SOT205-1	133E01A					92-11-17 95-02-04

Low voltage 8-bit microcontrollers with
UART and I²C-bus

P83CL781; P83CL782

QFP44: plastic quad flat package; 44 leads (lead length 1.3 mm); body 10 x 10 x 1.75 mm

SOT307-2

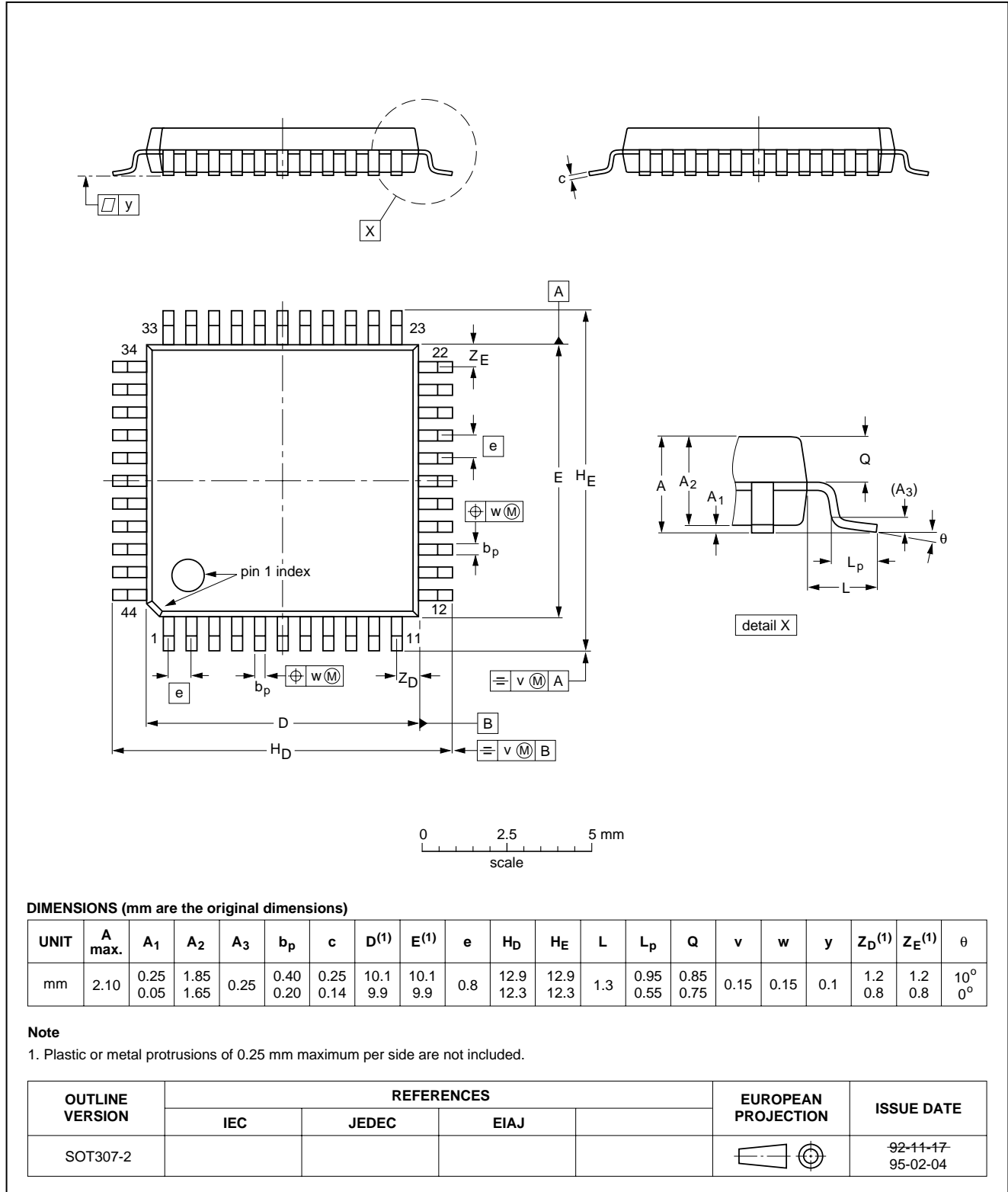

Low voltage 8-bit microcontrollers with UART and I²C-bus

P83CL781; P83CL782

24 SOLDERING

24.1 Introduction

There is no soldering method that is ideal for all IC packages. Wave soldering is often preferred when through-hole and surface mounted components are mixed on one printed-circuit board. However, wave soldering is not always suitable for surface mounted ICs, or for printed-circuits with high population densities. In these situations reflow soldering is often used.

This text gives a very brief insight to a complex technology. A more in-depth account of soldering ICs can be found in our *"IC Package Databook"* (order code 9398 652 90011).

24.2 DIP

24.2.1 SOLDERING BY DIPPING OR BY WAVE

The maximum permissible temperature of the solder is 260 °C; solder at this temperature must not be in contact with the joint for more than 5 seconds. The total contact time of successive solder waves must not exceed 5 seconds.

The device may be mounted up to the seating plane, but the temperature of the plastic body must not exceed the specified maximum storage temperature ($T_{stg\ max}$). If the printed-circuit board has been pre-heated, forced cooling may be necessary immediately after soldering to keep the temperature within the permissible limit.

24.2.2 REPAIRING SOLDERED JOINTS

Apply a low voltage soldering iron (less than 24 V) to the lead(s) of the package, below the seating plane or not more than 2 mm above it. If the temperature of the soldering iron bit is less than 300 °C it may remain in contact for up to 10 seconds. If the bit temperature is between 300 and 400 °C, contact may be up to 5 seconds.

24.3 QFP

24.3.1 REFLOW SOLDERING

Reflow soldering techniques are suitable for all QFP packages.

The choice of heating method may be influenced by larger plastic QFP packages (44 leads, or more). If infrared or vapour phase heating is used and the large packages are not absolutely dry (less than 0.1% moisture content by weight), vaporization of the small amount of moisture in them can cause cracking of the plastic body. For more information, refer to the Drypack chapter in our *"Quality Reference Handbook"* (order code 9398 510 63011).

Reflow soldering requires solder paste (a suspension of fine solder particles, flux and binding agent) to be applied to the printed-circuit board by screen printing, stencilling or pressure-syringe dispensing before package placement.

Several techniques exist for reflowing; for example, thermal conduction by heated belt. Dwell times vary from 50 to 300 seconds depending on heating method. Typical reflow temperatures range from 215 to 250 °C.

Preheating is necessary to dry the paste and evaporate the binding agent. Preheat for 45 minutes at 45 °C.

24.3.2 WAVE SOLDERING

Wave soldering is **not** recommended for QFP packages. This is because of the likelihood of solder bridging due to closely-spaced leads and the possibility of incomplete solder penetration in multi-lead devices.

If wave soldering cannot be avoided, the following conditions must be observed:

- **A double-wave (a turbulent wave with high upward pressure followed by a smooth laminar wave) soldering technique should be used.**
- **The footprint must be at an angle of 45° to the board direction and must incorporate solder thieves downstream and at the side corners.**

Even with these conditions, do not consider wave soldering the following packages: QFP52 (SOT379-1), QFP100 (SOT317-1), QFP100 (SOT317-2), QFP100 (SOT382-1) or QFP160 (SOT322-1).

During placement and before soldering, the package must be fixed with a droplet of adhesive. The adhesive can be applied by screen printing, pin transfer or syringe dispensing. The package can be soldered after the adhesive is cured. Maximum permissible solder temperature is 260 °C, and maximum duration of package immersion in solder is 10 seconds, if cooled to less than 150 °C within 6 seconds. Typical dwell time is 4 seconds at 250 °C.

A mildly-activated flux will eliminate the need for removal of corrosive residues in most applications.

24.3.3 REPAIRING SOLDERED JOINTS

Fix the component by first soldering two diagonally-opposite end leads. Use only a low voltage soldering iron (less than 24 V) applied to the flat part of the lead. Contact time must be limited to 10 seconds at up to 300 °C. When using a dedicated tool, all other leads can be soldered in one operation within 2 to 5 seconds between 270 and 320 °C.

Low voltage 8-bit microcontrollers with UART and I²C-bus

P83CL781; P83CL782

25 DEFINITIONS

Data sheet status	
Objective specification	This data sheet contains target or goal specifications for product development.
Preliminary specification	This data sheet contains preliminary data; supplementary data may be published later.
Product specification	This data sheet contains final product specifications.
Limiting values	
Limiting values given are in accordance with the Absolute Maximum Rating System (IEC 134). Stress above one or more of the limiting values may cause permanent damage to the device. These are stress ratings only and operation of the device at these or at any other conditions above those given in the Characteristics sections of the specification is not implied. Exposure to limiting values for extended periods may affect device reliability.	
Application information	
Where application information is given, it is advisory and does not form part of the specification.	

26 LIFE SUPPORT APPLICATIONS

These products are not designed for use in life support appliances, devices, or systems where malfunction of these products can reasonably be expected to result in personal injury. Philips customers using or selling these products for use in such applications do so at their own risk and agree to fully indemnify Philips for any damages resulting from such improper use or sale.

27 PURCHASE OF PHILIPS I²C COMPONENTS



Purchase of Philips I²C components conveys a license under the Philips' I²C patent to use the components in the I²C system provided the system conforms to the I²C specification defined by Philips. This specification can be ordered using the code 9398 393 40011.

Low voltage 8-bit microcontrollers with
UART and I²C-bus

P83CL781; P83CL782

NOTES

Low voltage 8-bit microcontrollers with
UART and I²C-bus

P83CL781; P83CL782

NOTES

Philips Semiconductors – a worldwide company

Argentina: see South America

Australia: 34 Waterloo Road, NORTH RYDE, NSW 2113,
Tel. +61 2 9805 4455, Fax. +61 2 9805 4466

Austria: Computerstr. 6, A-1101 WIEN, P.O. Box 213,
Tel. +43 1 60 101, Fax. +43 1 60 101 1210

Belarus: Hotel Minsk Business Center, Bld. 3, r. 1211, Volodarski Str. 6,
220050 MINSK, Tel. +375 172 200 733, Fax. +375 172 200 773

Belgium: see The Netherlands

Brazil: see South America

Bulgaria: Philips Bulgaria Ltd., Energoproject, 15th floor,
51 James Bourchier Blvd., 1407 SOFIA,
Tel. +359 2 689 211, Fax. +359 2 689 102

Canada: PHILIPS SEMICONDUCTORS/COMPONENTS,
Tel. +1 800 234 7381

China/Hong Kong: 501 Hong Kong Industrial Technology Centre,
72 Tat Chee Avenue, Kowloon Tong, HONG KONG,
Tel. +852 2319 7888, Fax. +852 2319 7700

Colombia: see South America

Czech Republic: see Austria

Denmark: Prags Boulevard 80, PB 1919, DK-2300 COPENHAGEN S,
Tel. +45 32 88 2636, Fax. +45 31 57 1949

Finland: Sinikalliontie 3, FIN-02630 ESPOO,
Tel. +358 9 615800, Fax. +358 9 61580/xxx

France: 4 Rue du Port-aux-Vins, BP317, 92156 SURESNES Cedex,
Tel. +33 1 40 99 6161, Fax. +33 1 40 99 6427

Germany: Hammerbrookstraße 69, D-20097 HAMBURG,
Tel. +49 40 23 53 60, Fax. +49 40 23 536 300

Greece: No. 15, 25th March Street, GR 17778 TAVROS/ATHENS,
Tel. +30 1 4894 339/239, Fax. +30 1 4814 240

Hungary: see Austria

India: Philips INDIA Ltd, Shivsagar Estate, A Block, Dr. Annie Besant Rd.
Worli, MUMBAI 400 018, Tel. +91 22 4938 541, Fax. +91 22 4938 722

Indonesia: see Singapore

Ireland: Newstead, Clonskeagh, DUBLIN 14,
Tel. +353 1 7640 000, Fax. +353 1 7640 200

Israel: RAPAC Electronics, 7 Kehilat Saloniki St, TEL AVIV 61180,
Tel. +972 3 645 0444, Fax. +972 3 649 1007

Italy: PHILIPS SEMICONDUCTORS, Piazza IV Novembre 3,
20124 MILANO, Tel. +39 2 6752 2531, Fax. +39 2 6752 2557

Japan: Philips Bldg 13-37, Kohnan 2-chome, Minato-ku, TOKYO 108,
Tel. +81 3 3740 5130, Fax. +81 3 3740 5077

Korea: Philips House, 260-199 Itaewon-dong, Yongsan-ku, SEOUL,
Tel. +82 2 709 1412, Fax. +82 2 709 1415

Malaysia: No. 76 Jalan Universiti, 46200 PETALING JAYA, SELANGOR,
Tel. +60 3 750 5214, Fax. +60 3 757 4880

Mexico: 5900 Gateway East, Suite 200, EL PASO, TEXAS 79905,
Tel. +9-5 800 234 7381

Middle East: see Italy

Netherlands: Postbus 90050, 5600 PB EINDHOVEN, Bldg. VB,
Tel. +31 40 27 82785, Fax. +31 40 27 88399

New Zealand: 2 Wagener Place, C.P.O. Box 1041, AUCKLAND,
Tel. +64 9 849 4160, Fax. +64 9 849 7811

Norway: Box 1, Manglerud 0612, OSLO,
Tel. +47 22 74 8000, Fax. +47 22 74 8341

Philippines: Philips Semiconductors Philippines Inc.,
106 Valero St. Salcedo Village, P.O. Box 2108 MCC, MAKATI,
Metro MANILA, Tel. +63 2 816 6380, Fax. +63 2 817 3474

Poland: Ul. Lukiska 10, PL 04-123 WARSZAWA,
Tel. +48 22 612 2831, Fax. +48 22 612 2327

Portugal: see Spain

Romania: see Italy

Russia: Philips Russia, Ul. Usatcheva 35A, 119048 MOSCOW,
Tel. +7 095 755 6918, Fax. +7 095 755 6919

Singapore: Lorong 1, Toa Payoh, SINGAPORE 1231,
Tel. +65 350 2538, Fax. +65 251 6500

Slovakia: see Austria

Slovenia: see Italy

South Africa: S.A. PHILIPS Pty Ltd., 195-215 Main Road Martindale,
2092 JOHANNESBURG, P.O. Box 7430 Johannesburg 2000,
Tel. +27 11 470 5911, Fax. +27 11 470 5494

South America: Rua do Rocio 220, 5th floor, Suite 51,
04552-903 São Paulo, SÃO PAULO - SP, Brazil,
Tel. +55 11 821 2333, Fax. +55 11 829 1849

Spain: Balmes 22, 08007 BARCELONA,
Tel. +34 3 301 6312, Fax. +34 3 301 4107

Sweden: Kottbygatan 7, Akalla, S-16485 STOCKHOLM,
Tel. +46 8 632 2000, Fax. +46 8 632 2745

Switzerland: Allmendstrasse 140, CH-8027 ZÜRICH,
Tel. +41 1 488 2686, Fax. +41 1 481 7730

Taiwan: Philips Semiconductors, 6F, No. 96, Chien Kuo N. Rd., Sec. 1,
TAIPEI, Taiwan Tel. +886 2 2134 2870, Fax. +886 2 2134 2874

Thailand: PHILIPS ELECTRONICS (THAILAND) Ltd.,
209/2 Sanpavuth-Bangna Road Prakanong, BANGKOK 10260,
Tel. +66 2 745 4090, Fax. +66 2 398 0793

Turkey: Talatpasa Cad. No. 5, 80640 GÜLTEPE/ISTANBUL,
Tel. +90 212 279 2770, Fax. +90 212 282 6707

Ukraine: PHILIPS UKRAINE, 4 Patrice Lumumba str., Building B, Floor 7,
252042 KIEV, Tel. +380 44 264 2776, Fax. +380 44 268 0461

United Kingdom: Philips Semiconductors Ltd., 276 Bath Road, Hayes,
MIDDLESEX UB3 5BX, Tel. +44 181 730 5000, Fax. +44 181 754 8421

United States: 811 East Arques Avenue, SUNNYVALE, CA 94088-3409,
Tel. +1 800 234 7381

Uruguay: see South America

Vietnam: see Singapore

Yugoslavia: PHILIPS, Trg N. Pasica 5/v, 11000 BEOGRAD,
Tel. +381 11 625 344, Fax. +381 11 635 777

For all other countries apply to: Philips Semiconductors, Marketing & Sales Communications,
Building BE-p, P.O. Box 218, 5600 MD EINDHOVEN, The Netherlands, Fax. +31 40 27 24825

Internet: <http://www.semiconductors.philips.com>

© Philips Electronics N.V. 1997

SCA53

All rights are reserved. Reproduction in whole or in part is prohibited without the prior written consent of the copyright owner.

The information presented in this document does not form part of any quotation or contract, is believed to be accurate and reliable and may be changed without notice. No liability will be accepted by the publisher for any consequence of its use. Publication thereof does not convey nor imply any license under patent- or other industrial or intellectual property rights.

Printed in The Netherlands

457047/1200/02/pp76

Date of release: 1997 Mar 14

Document order number: 9397 750 01511

Let's make things better.

**Philips
Semiconductors**



PHILIPS